

Operating and installation instructions

Frost free fridge freezer



To avoid the risk of accidents or damage to the appliance, it is **essential** to read these instructions before it is installed and used for the first time.

Contents

Description of the appliance	5
Caring for the environment	7
Warning and Safety instructions	8
How to save energy	17
Switching on and off	19
Switching on	19
Operation	19
Switching off	20
Settings mode	21
Switching off for longer periods of time	22
The correct temperature	23
. . . in the refrigerator and the MasterFresh zone	23
Dynamic cooling	23
. . . in the freezer	23
Setting the temperature in the refrigerator/freezer zones	24
Temperature range	24
Temperature (Fahrenheit/Celsius)	25
Temperature display	26
Alarm	27
Super cool and Super freeze	29
Super cool	29
Super freeze	30
Storing food in the refrigerator section	31
Different storage zones	31
Food which is not suitable for storing in a refrigerator	33
When shopping for food	33
Storing food correctly	33
Storing food in the MasterFresh zone	34
Storage temperature	34
Humidity level	34
Storing food in the MasterFresh zone	34

Arranging the interior fittings	37
Moving the shelves	37
Floating deli drawer	37
The MasterFresh drawer	37
Adjusting the door shelves/bottle shelf	38
To remove the shelf above the MasterFresh drawer	39
Small freezer basket	39
Large freezer basket with dividing panel	40
Freezing and storing food	41
Maximum freezing capacity	41
Freezing fresh food	41
Storing frozen food	41
Home freezing	42
Defrosting	43
Cooling drinks	44
Making ice cubes	45
Defrosting	47
Cleaning and care	48
Before cleaning	48
Cleaning the interior and accessories	48
Ice cube container	49
Humidity filters	50
Ventilation gaps	50
Door seals	51
Problem solving guide	52
Water filter	57
Reminder to change the water filter	57
To change the water filter	58
To confirm that the water filter has been changed	59
Using an external water filter	59
Noises	60
After Sales / Guarantee	61
Guarantee	61
Note for test institutes	62

Contents

Mains water connection	63
Notes on connecting to the mains water supply	63
Preparing for plumbing the appliance into the mains water supply	64
Fitting the stainless steel hose to the appliance	66
Electrical connection	67
Installation advice	68
Location	68
Climate range	68
Floor	70
Door hinging	70
Adjoining furniture/units	70
Ventilation	70
Side-by-side installation	70
To limit the opening angle of the door	72
Appliance door dimensions (opening angle 90°)	73
Appliance door dimensions (opening angle 115°)	73
Building-in dimensions	74
Installation	76
Tools and accessories required	76
Weight of the door/drawer fronts	77
Building into a peninsular run	77
Building-in at the end of a run of units	77
Aligning the building-in niche	78
Checking the building-in niche	78
Before installation	78
Preparing the niche	79
Installation accessories	79
Anti-tipping mechanism	80
An alternative anti-tipping mechanism	82
Placing the appliance in the niche	83
Aligning the appliance	84
Securing the appliance in the niche	85
Preparing the furniture front	87
Securing and aligning the furniture door	89
Securing the covers	91
Fitting the plinth facing	92
Fitting the air separator	93
Addresses	95

Description of the appliance

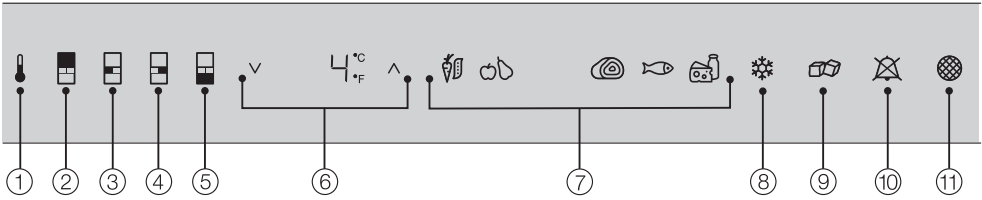

- ① Access sensor
- ② Sensor for selecting the refrigerator zone
- ③ Sensor for selecting the left-hand MasterFresh drawer
- ④ Sensor for selecting the right-hand MasterFresh drawer
- ⑤ Sensor for selecting the freezer zone
- ⑥ Sensor for selecting the temperature in the refrigerator or freezer zone (V for colder; ^ for warmer)
- ⑦ Symbols for food that requires a moist atmosphere in the MasterFresh zone (left: High humidity; right: Low humidity)
- ⑧ On/Off sensor for the Super cool and Super freeze functions
- ⑨ On/Off sensor for the ice cube maker (only visible if the freezer zone has been selected)
- ⑩ Sensor for switching off the temperature or door alarm (only visible when the temperature or door alarm is sounding)
- ⑪ Reminder to change the water filter

Description of the appliance

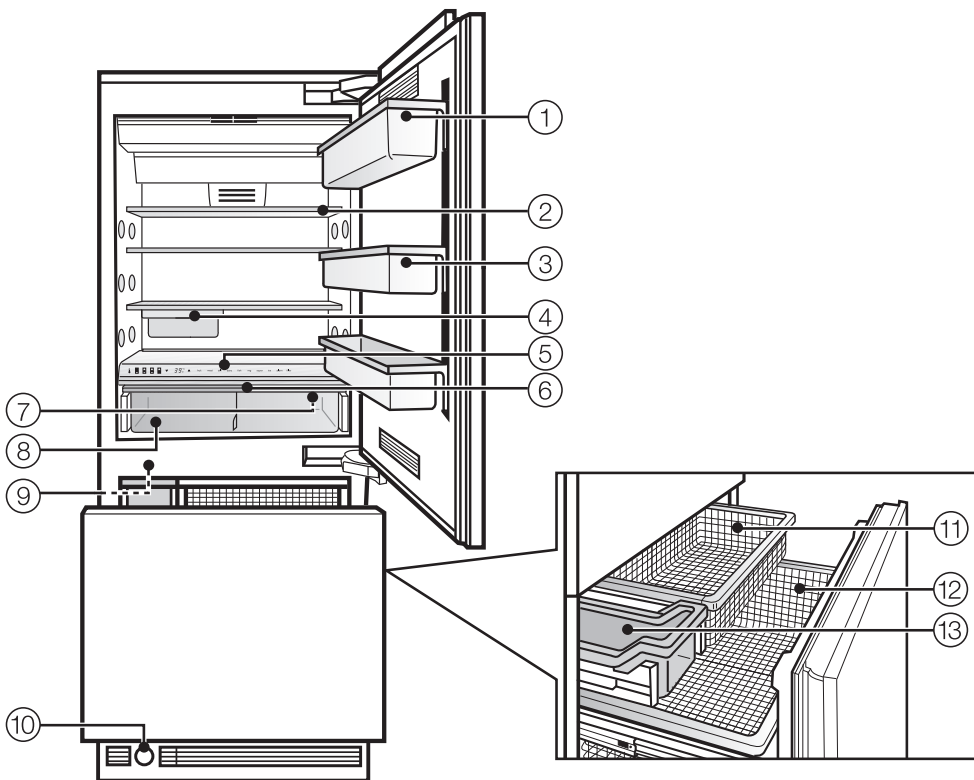

- ① Butter and cheese compartment
- ② Adjustable shelves
- ③ Door shelf
- ④ Floating deli drawer
- ⑤ Control panel
- ⑥ Humidity filters for the MasterFresh zone

- ⑦ Switch for switching the whole appliance on and off
- ⑧ MasterFresh zone
- ⑨ Ice maker
- ⑩ Water filter
- ⑪ Small freezer basket
- ⑫ Large freezer basket
- ⑬ Ice cube container

Disposing of the packaging materials

The packaging is designed to protect the appliance from damage during transportation. The packaging materials used are selected from materials which are environmentally friendly for disposal and should be recycled.

Recycling the packaging reduces the use of raw materials in the manufacturing process and also reduces the amount of waste in landfill sites.

Disposing of your old appliance

Electrical and electronic appliances often contain valuable materials. They also contain materials which, if handled or disposed of incorrectly, could be potentially hazardous to human health and to the environment. They are, however, essential for the correct functioning of your appliance. Please do not therefore dispose of it with your household waste.

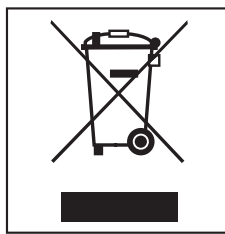

Please dispose of it at your local community waste collection / recycling centre.

Take care not to damage the pipework at the back of it before or during transportation to an authorised collection depot. In this way, refrigerant in the pipework and oil in the compressor will be contained, and will not leak into the environment.

Please ensure that your old appliance presents no danger to children while being stored awaiting disposal. See "Warning and Safety instructions" for more information.

Warning and Safety instructions

This appliance complies with all statutory safety requirements. Inappropriate use can, however, lead to personal injury and damage to property.

To avoid the risk of accidents and damage to the appliance, please read these instructions carefully before installation and before using it for the first time. They contain important information on installation, safety, use and maintenance.

Miele cannot be held liable for damage caused by non-compliance with these Warning and Safety instructions.

Keep these instructions in a safe place and ensure that new users are familiar with the content. Pass them on to any future owner.

Warning!

This appliance is very heavy and can tip forwards when the door is open. Keep the appliance door shut until the appliance has been built in and secured in its building-in niche in accordance with these operating and installation instructions.

Correct application

▶ The appliance is intended for use in domestic households and similar working and residential environments. It is not intended for outdoor use.

▶ This appliance is intended for domestic use only for cooling and storing food and drink as well as for storing deep frozen food, freezing fresh food and for making ice.

Any other usage is not supported by the manufacturer and could be dangerous.

Warning and Safety instructions

▶ The appliance is not suitable for storing and keeping cool medicines, blood plasma, laboratory preparations or other such materials or products. Incorrect use of the appliance for such purposes can cause deterioration of the items stored. The appliance is also not suitable for use in areas susceptible to explosion. Miele cannot be held liable for any damage resulting from incorrect or improper use or operation.

▶ The appliance can only be used by people with reduced physical, sensory or mental capabilities, or lack of experience and knowledge, if they are supervised whilst using it, or have been shown how to use it in a safe way and recognise and understand the consequences of incorrect operation.

Safety with children

▶ Children under 8 years of age must be kept away from the appliance unless they are constantly supervised.

▶ Children 8 years and older may only use the appliance unsupervised if they have been shown how to use it in a safe way and recognise and understand the consequences of incorrect operation.

▶ Children must not be allowed to clean or maintain the appliance unsupervised.

▶ Please supervise children in the vicinity of the appliance and do not let them play with it.

▶ The door hinges can cause injury. Keep children well away at all times.

▶ Please bear in mind that by removing the dividing panel in the large freezer basket, children may be tempted to climb inside. **THIS COULD PUT THEIR LIVES IN DANGER.**

Warning and Safety instructions

▶ Danger of suffocation. Packaging, e.g. plastic wrappings, must be kept out of the reach of babies and children. Whilst playing, children could become entangled in packaging or pull it over their head and suffocate.

Technical safety

▶ The coolant system is tested for leaks. The appliance complies with statutory safety requirements and the appropriate EU guidelines.



R600a

▶ This appliance contains the coolant Isobutane (R600a), a natural gas which is environmentally friendly. Although it is flammable, it does not damage the ozone layer and does not increase the greenhouse effect. The use of this coolant has, however, led to a slight increase in the noise level of the appliance. In addition to the noise of the compressor, you might be able to hear the coolant flowing around the system. This is unavoidable, and does not have any adverse effect on the performance of the appliance.

Care must be taken during the transportation and installation of the appliance that no parts of the cooling system are damaged.

Splashes of coolant can injure the eyes.

In the event of any damage:

Warning and Safety instructions

- avoid any open flames or anything which creates a spark,
- disconnect the appliance from the electricity supply,
- ventilate the room where the appliance is located for several minutes, and
- contact the Service Department for advice.

▶ The more coolant there is in an appliance, the larger the room it should be installed in. In the event of a leakage, if the appliance is in a small room, there is the danger of combustible gases building up. For every 8 g of coolant at least 1 m³ of room space is required. The amount of coolant in the appliance is stated on the data plate inside the appliance.

▶ To avoid the risk of damage to the appliance, make sure that the connection data (fuse rating, frequency and voltage) on the data plate corresponds to the household supply. Check that this is the case before connecting the appliance. Consult a qualified electrician if in any doubt.

▶ The electrical safety of this appliance can only be guaranteed when it is correctly earthed. It is essential that this standard safety requirement is met. If in any doubt, please have the electrical installation tested by a qualified electrician.

▶ If the electrical connection cable is faulty it must only be replaced by a Miele authorised service technician to protect the user from danger.

▶ Do not connect the appliance to the mains electrical supply by an extension lead or multi-socket adapter. These are a fire hazard and do not guarantee the required safety of the appliance.

Warning and Safety instructions

- ▶ Do not use in a damp or wet environment (e.g. garage or utility room). Moisture could reach live components or the electrical connection and cause a short circuit.
- ▶ This appliance must not be used in a non-stationary location (e.g. on a ship).
- ▶ A damaged appliance can be dangerous. Check the appliance for visible signs of damage. Do not use a damaged appliance.
- ▶ For safety reasons, this appliance may only be used when it has been fully installed.
- ▶ The appliance must be disconnected from the mains electricity supply during installation, maintenance and repair work. Ensure that power is not supplied to the appliance until after it has been installed or until after any maintenance or repair work has been carried out.
- ▶ Unauthorised installation, maintenance and repairs can cause considerable danger to users. Installation, maintenance and repair work must only be carried out by a Miele authorised technician.
- ▶ While the appliance is under guarantee, repairs should only be undertaken by a Miele authorised service technician. Otherwise the guarantee is invalidated.

Warning and Safety instructions

- ▶ The manufacturer can only guarantee the safety of the appliance when original Miele replacement parts are used. Faulty components must only be replaced by genuine Miele original spare parts.
- ▶ The manufacturer cannot be held liable for damage caused by a faulty connection to the mains water supply.
- ▶ Connection to the mains water supply and any repairs to the ice cube maker must only be carried out by a suitably qualified and competent person.
- ▶ The ice cube maker is not suitable for connection to a hot water supply.
- ▶ Before making plumbing connections, ensure that the appliance is disconnected from the mains electrical supply.
- ▶ Never tamper with the movable components on the ice cube maker, including the ice cube expulsion mechanism or the element on the ice cube maker. Danger of injury.

Correct use

- ▶ The appliance is designed for use within certain climate ranges (ambient temperatures), and should not be used outside this range. The climate range of the appliance is stated on the data plate inside the appliance. Installing it in a room with too low an ambient temperature, e.g. a garage, will lead to the compressor switching off for longer periods so that the appliance cannot maintain the required temperature.
- ▶ Do not cover or block the air vents as this could impair the efficiency of the appliance, increase the electricity consumption and could cause damage to the appliance.

Warning and Safety instructions

- ▶ If storing food which contains a lot of fat or oil in the appliance or the door, make sure that it does not come into contact with plastic components as this could cause stress cracks or break the plastic.
- ▶ Do not store explosive materials in the appliance or any products containing propellants (e.g. spray cans). Electrical components could cause flammable vapours to ignite. Danger of sparking and explosion.
- ▶ Do not operate any electrical equipment (e.g. an electric ice-cream maker) inside the appliance. Danger of sparking and explosion.
- ▶ Do not store cans or bottles containing carbonated drinks or liquids which could freeze in the freezer. The cans or bottles could explode. causing injury or damage.
- ▶ If storing alcohol with a high percentage proof, make sure it is tightly closed and stored upright. Danger of explosion.
- ▶ When cooling drinks quickly in the freezer, make sure bottles are not left in for more than one hour; otherwise they could burst, causing injury or damage.
- ▶ Never handle frozen food or the metal parts of the appliance with wet hands. Your hands may freeze to the frozen food or metal parts. Danger of frost burn.
- ▶ Do not take ice cubes out with your bare hands and never place ice cubes or ice lollies in your mouth straight from the freezer. The very low temperature of the frozen ice or lollies can cause frostburn to the lips or tongue.
- ▶ Do not refreeze partially or fully defrosted food. Consume defrosted food as soon as possible, as it will lose its nutritional value and spoil if left for too long. Defrosted food may only be re-frozen after it has been cooked.

Warning and Safety instructions

- ▶ Observe the manufacturer's "use-by" dates and storage instructions given on food to avoid the risk of food poisoning. Storage times will depend on several factors, including the freshness and quality of the food as well as the temperature at which it is stored. Follow the instructions given on the food manufacturer's packaging regarding storage conditions and "use-by" dates.
- ▶ To avoid the risk of any potential illness, do not deactivate the reminder to change the water filter.
- ▶ Only use genuine original Miele accessories with this appliance. Using spare parts or accessories from other manufacturers will invalidate the guarantee, and Miele cannot accept liability.

Cleaning and care

- ▶ Do not use any oils or grease on the door seals, as these will cause the seals to deteriorate and become porous with time.
- ▶ Do not use a steam cleaning appliance to clean or defrost this appliance. Steam could reach electrical components and cause a short circuit.
- ▶ Do not use sharp edged objects to
 - remove frost and ice,
 - lift frozen food and remove ice trays.They will damage the evaporator, causing irreversible damage to the appliance.
- ▶ Never place electric heaters or candles in the appliance to defrost it. These can damage the plastic parts.
- ▶ Do not use defrosting sprays or de-icers, as they might contain substances which could damage the plastic parts or which could cause a build-up of gases and pose a danger to health.

Warning and Safety instructions

Disposal of your old appliance

▶ Before disposing of an old appliance, first make the door latch or lock unusable.

This way you will prevent children from accidentally locking themselves in and endangering their lives.

▶ Be careful not to damage any part of the pipework whilst awaiting disposal, e.g. by

- puncturing the refrigerant channels in the evaporator,
- bending any pipework,
- scratching the surface coating.

Leaking refrigerant can damage the eyes.

How to save energy

	Normal energy consumption	Increased energy consumption
Installation site / Maintenance	In a ventilated room.	In an enclosed, unventilated room.
	Protected from direct sunlight.	In direct sunlight.
	Not near to a heat source (radiator, oven).	Near to a heat source (radiator, oven).
	Where the ideal ambient room temperature is approx. 20 °C.	Where there is a high ambient room temperature.
	Ventilation gaps uncovered and dusted regularly.	Ventilation gaps covered up or dusty.
Temperature setting	Refrigerator section 4 to 5 °C	With a low temperature setting: The colder the temperature in the refrigerator / freezer section, the higher the energy consumption.
	MasterFresh zone approx. 1.5 °C	
	Freezer section -18°C	

How to save energy

	Normal energy consumption	Increased energy consumption
Use	Drawers, shelves and racks arranged as they were when the appliance was delivered.	
	Only open the door when necessary and for as short a time as possible. Store food in an organised way.	Frequent opening of the door for long periods will cause a loss of coldness. The appliance works harder to cool down and the compressor runs for longer periods.
	Take an insulated cool bag with you when shopping and place food in the appliance as soon as possible. Replace any food removed as quickly as possible, before it begins to thaw. Allow hot food and drinks to cool down before placing them in the appliance.	Hot food or food at room temperature raises the temperature inside the appliance. The appliance works harder to cool down and the compressor runs for longer periods.
	Store food covered or packaged.	The evaporation or condensation of liquids will cause a loss of coldness in the refrigerator.
	Place frozen food in the refrigerator to defrost.	
	Do not over-fill the appliance to allow air to circulate.	

Before using for the first time

- Clean the inside of the appliance and the accessories with lukewarm water and a little washing up liquid, and then dry with a soft cloth.

Important:

To ensure the correct functioning of the appliance, let it stand for approx. 8 hours if it has been transported on its side to its final location before connecting it to the mains.

To enable the temperature to get sufficiently cold inside the appliance, allow the appliance to run for a few hours before placing food in it.

Do not place food in the freezer until the temperature is at least -18°C .

Please note: Switching the appliance off with the rocker switch does not disconnect the appliance from the mains.

Switching on

- Open the upper door.



- Press the rocker switch on the right side underneath the control panel.

This switches all of the zones in the appliance on or off together.

The appliance will start to cool, and the interior lighting will come on when the door is opened.



The access sensor in the control panel will also light up.

Operation

A light touch of the finger on the sensors is all that is required to operate this appliance.

Please note:

- A sensor which is **available** for selection is always highlighted in **white**.
- A sensor which has been **selected** is always highlighted in **yellow**.



- Touch the access sensor so that it is highlighted in yellow.



The sensors for the four zones in the appliance will now appear in the control panel: refrigerator zone, left- and right-hand MasterFresh compartments and freezer zone.

Switching on and off



The sensor for switching the ice cube maker on and off will appear on the right in the control panel (only visible if the freezer zone has been selected).

This sensor will be highlighted in yellow when the ice cube maker is in operation.

To select settings for your appliance (e.g. to set the temperature, etc),

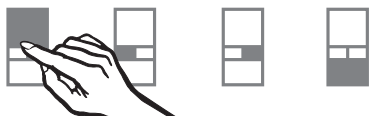

- touch the sensor for the particular zone of the appliance where you would like to select the settings.

The applicable sensor will then be highlighted in yellow, and depending on the zone, further settings which may be selected will now appear in the display.

Depending on which zone you have selected, you can

- adjust the temperature, or
- select Super cool and Super freeze
- adjust the humidity levels for the MasterFresh zone
- switch on the ice cube maker.

Please refer to the relevant section for more information.

To deselect a zone

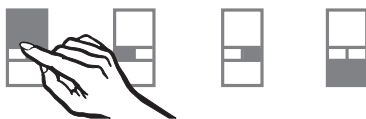

- touch the sensor of the selected zone again so that it is highlighted in white, or select a different sensor.

To finish selecting settings,



- touch the access sensor so that it is highlighted in white.

Your last selected settings will now be saved to memory.

If you do not touch the access sensor, the electronics for accessing the settings will switch off after a period.

Switching off



- Press the rocker switch on the right-hand side underneath the control panel.

The cooling system and the lighting are now switched off.

Settings mode

You can select further settings in settings mode and then select certain appliance functions and adjust their settings. The settings for the different functions are described in more detail in the relevant section of these instructions.

Overview of functions that can be selected in settings mode:

Function	Symbol
To enter or leave settings mode	<i>c</i>
To select the temperature unit (see "The correct temperature")	<i>t</i>
No function allocated	<i>r</i>
To switch the sensor tone on/off (see "Switching on and off")	<i>b</i>
No function selected	<i>h</i>

Switching the sensor tone on/off

The tone which sounds each time a sensor is touched can be deactivated.



- Touch the access sensor to highlight it in yellow.

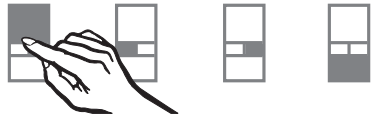

- Touch the sensor for the refrigerator zone so that it is highlighted in yellow.
- Take note of the position of the ∇ sensor (but do not touch it!).
- Touch the access sensor until it is highlighted in white and all of the other sensors are no longer lit up.
- Place your finger in the position of the ∇ sensor, and leave it there.
- At the same time, briefly touch the access sensor (without moving your finger from the ∇ sensor).

Switching on and off

- Leave your finger on the √ sensor for another 4 seconds until **c** and the ^ sensor also appear in the display.



- Now touch the √ sensor repeatedly until **b** appears in the display.
- Touch the access sensor again.
- By touching the √ sensor, you can now select whether the sensor tone is switched on or off:
 - b 0**: Sensor tone switched off
 - b 1**: Sensor tone switched on
 - b -**: Return to menu
- After selecting a new setting, touch the access sensor to confirm your choice.
- Touch the √ sensor repeatedly until **c** appears in the display.



- Touch the access sensor.

You have now left settings mode.

The door alarm is automatically disabled when the appliance is in settings mode. As soon as the door is closed, the door alarm is activated again.

Switching off for longer periods of time

If the appliance is not going to be used for a longer period of time, e.g. whilst on holiday:

- switch the appliance off,
- disconnect it from the mains,
- turn off the stopcock to the water supply (a few hours before you switch off the appliance),
- empty the ice cube container,
- clean the appliance out,
- replace the water filter and
- leave the doors ajar to air the appliance.

If, during a long absence, the appliance is switched off but not cleaned out and the door and drawer are left shut, there is a danger of mould and odours building up inside the appliance.

The correct temperature

It is very important to set the correct temperature for storing food in the appliance. Micro-organisms will cause food which is not stored at the correct temperature to deteriorate rapidly. Temperature influences the growth rate of these micro-organisms. Reducing the temperature reduces their growth rate.

The temperature in the appliance will rise:

- the more often the door is opened and the longer it is kept open,
- the more food that is stored in it,
- the warmer the food is which is being put into it,

– the higher the ambient temperature surrounding the appliance.
The appliance is designed for use in specific ambient temperatures (climate ranges). Do not use in ambient temperatures for which it is not designed.

. . . in the refrigerator and the MasterFresh zone

We recommend a temperature of **4 °C** in the refrigerator.

The temperature in the MasterFresh zone is controlled automatically and is maintained at **1.5 °C**.

Dynamic cooling

The dynamic cooling fan automatically switches on when the cooling system for the refrigerator switches on. It distributes the temperature in the appliance to all areas more evenly so that all the food will be chilled to about the same degree.

. . . in the freezer

To freeze fresh food and to store frozen food for a long time, a temperature of **-18 °C** is required. At this temperature the growth of micro-organisms is generally halted. As soon as the temperature rises above -10 °C, the micro-organisms become active in the food again so that it cannot be kept as long. For this reason, partially defrosted or defrosted food must not be re-frozen. Food may be re-frozen once it has been cooked, as the high temperatures achieved when cooking destroy most micro-organisms.

The correct temperature

Setting the temperature in the refrigerator/freezer zones

The temperatures in the refrigerator and freezer zones are set independently of one another.



- Touch the access sensor so that it is highlighted in yellow.

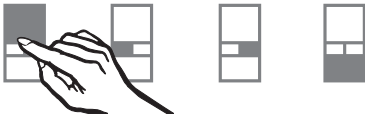

- Touch the sensor for the refrigerator or freezer zone so that it is highlighted in yellow.



- The temperature inside the appliance can be selected by touching the arrow sensors on either side of the temperature display.

By touching the

- ∨ sensor: the temperature will get colder
- ∧ sensor: the temperature will get warmer.

The temperature range being set will flash in the display as you do this.

- Touching the sensor once: adjusts the temperature shown in 1 °C steps.
- Keeping your finger on the sensor: changes the temperature continuously.

If the highest or lowest temperature that it is possible to set is reached, the ∨ or ∧ sensor will disappear from the display.

The temperature display on the control panel always shows the **required** temperature.

When you have adjusted the temperature, **wait for approx. 6 hours if the appliance is not very full** and **for approx. 24 hours if the appliance is full** before checking the temperature, as it will take this long for the appliance to reach the temperature. If, after this time, the temperature is still too high or too low, you will need to adjust it again.

Temperature range

The temperature can be adjusted:

- In the refrigerator zone from 2 °C to 8 °C
- In the freezer zone from -14 °C to -24 °C.

The ambient temperature in the room and the installation location can affect the time it takes for the appliance to reach the lowest temperature. If the ambient temperature is too high, the appliance may not reach the lowest temperature.

The correct temperature

Temperature (Fahrenheit/Celsius)

The temperature can be displayed in degrees Celsius or degrees Fahrenheit.



- Touch the access sensor so that it is highlighted in yellow.

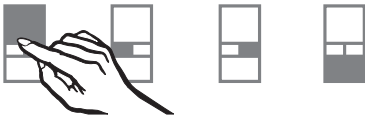

- Touch the sensor for the refrigerator zone so that it is highlighted in yellow.
- Take note of the position of the ∇ sensor (but do not touch it!).
- Touch the access sensor until it is highlighted in white and all of the other sensors are no longer lit up.
- Place your finger in the position of the ∇ sensor, and leave it there.
- At the same time, briefly touch the access sensor (without letting go of the ∇ sensor).
- Leave your finger on the ∇ sensor for another 4 seconds until ϵ and the \wedge sensor also appear in the display.



- Now touch the ∇ sensor repeatedly until f appears in the display.
- Touch the access sensor again.
- By touching the ∇ sensor, you can now set the temperature to be displayed in Fahrenheit or Celsius.
 $f \text{ } \bar{0}$: Temperature in Fahrenheit
 $f \text{ } 1$: Temperature in Celsius
 $f \text{ } -$: Return to menu.
- After selecting a new setting, touch the access sensor to confirm your choice.
- Now touch the ∇ sensor repeatedly until ϵ appears in the display.



- Touch the access sensor again.
- You have now left settings mode.

The door alarm is automatically disabled when the appliance is in settings mode. As soon as the door is closed, the door alarm is activated again.

The correct temperature

Temperature display

The temperature display on the control panel always shows the **required** temperature.

The **temperature displays flashes** if

- a different temperature is being set,
- the temperature in the appliance has risen by several degrees, indicating that the appliance is warming up too much.

This loss of coldness is no cause for concern in the following circumstances:

- when the door has been left open for a while, e.g. for removing or storing a large amount of food,
- when fresh food is being frozen.

However, if the temperature in the freezer zone remains above -18°C for a long time, check that the frozen food has not started to defrost. If it has, check that the food is safe to use and if it is, then use it as soon as possible.

Your appliance has been fitted with a warning system which ensures that the temperature in the appliance cannot rise unnoticed and to avoid energy being wasted if a door is left open.

Activating the alarm system

The alarm system is always active. It does not have to be switched on manually.

Temperature alarm

If the temperature in one of the zones gets too warm, the sensor for the zone concerned will flash in the control panel.

The sensor for switching the temperature or door alarm off will flash at the same time.

An audible alarm will also sound.

If the temperature rises in the freezer, the temperature display will show the highest temperature that was reached during the time the temperature in the freezer rose.

The alarm will sound and the relevant symbol will flash, for example,

- if the freezer drawer has been left open for a while, e.g. in order to load, re-arrange or take food out.
- when freezing large amounts of food at once.
- in the event of a power cut.

The alarm will stop and the sensor for switching the temperature or door alarm off in the display will go out again as soon as the temperature has dropped down to the correct level again. The sensor for the zone concerned will light up again constantly.

Switching the temperature alarm off early

If the noise disturbs you, you can switch the alarm off early if you wish.



- Touch the sensor for switching the temperature or door alarm off. The alarm will stop. The sensor for switching the temperature or door alarm off will continue to be lit up until the temperature has dropped down to the correct level again. The sensor for the zone concerned will continue to flash until the temperature is at the correct level.

However, if the temperature in the freezer section remains above -18 °C for a long time, check that the frozen food has not started to defrost. If it has, check that the food is safe to use and if it is, then use it as soon as possible.

Alarm

Door alarm

The alarm will sound if the door or drawer is left open for more than 5 minutes. The sensor for switching the temperature or door alarm off button will also light up.

The alarm will stop and the sensor for switching the temperature or door alarm in the display will go out again as soon as the door/drawer has been shut again.

Switching the door alarm off early

If the noise disturbs you, you can switch the alarm off early if you wish.



- Touch the sensor for switching the temperature or door alarm off.

The sensor for switching the temperature or door alarm off in the display will go out and the alarm will stop.

Super cool

The Super cool function can be used to rapidly reduce the temperature in the refrigerator to its lowest setting (depending on the room temperature).

Switching on Super cool

Super cool is particularly recommended for the faster chilling of large amounts of fresh food or drink.

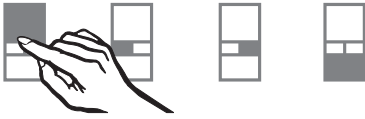

- Touch the sensor for the refrigerator zone so that it is highlighted in yellow.



- Touch the Super cool sensor so that it is highlighted in yellow.

The appliance will now operate at full power to lower the temperature in the refrigerator zone, and the newly set temperature of 2°C will show in the temperature display.

Switching off Super cool

The Super cool function will switch itself off automatically after approx. 6 hours. The sensor is highlighted in white and the appliance continues running at normal power.

To save energy, the Super cool function can be switched off once food and drinks are sufficiently chilled.



- Touch the Super cool sensor so that it is highlighted in white.

The original temperature will now appear in the temperature display for the refrigerator, and the appliance will continue to operate at normal power.

Super cool and Super freeze

Super freeze

Switch the Super freeze function on before putting fresh food into the freezer zone.

This helps food to freeze quickly and retain its nutrients, vitamins, flavours and appearance.

Super freeze is not necessary:

- when placing food in the freezer that is already frozen.
- when freezing less than 2 kg fresh food in any one day.

Switching on Super freeze

When freezing small quantities of food in the freezer, the Super freeze function should be switched on **4-6 hours beforehand**. When freezing **the maximum load of food** the Super freeze function should be switched on **24 hours beforehand**.

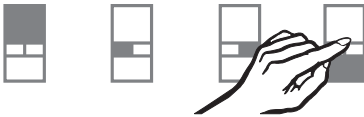

- Touch the sensor for the freezer zone so that it is highlighted in yellow.



- Touch the Super freeze sensor so that it lights up yellow.

The appliance will now operate at full power to lower the temperature in the freezer zone, and the newly set temperature of $-30\text{ }^{\circ}\text{C}$ will show in the temperature display.

Switching off Super freeze

Depending on the amount of food placed in the freezer section, the Super freeze function will switch off automatically after approx. 52 hours. The sensor is highlighted in white and the appliance continues running at normal power.

To save energy, the Super freeze function can be switched off once the temperature in the freezer is low enough.



- Touch the Super freeze sensor so that it is highlighted in white.

The original temperature will now appear in the temperature display for the freezer, and the appliance will continue to operate at normal power.

Storing food in the refrigerator section

Different storage zones

Due to the natural circulation of the air in the appliance, there are different temperature zones in the refrigerator. Cold, heavy air sinks to the lowest section of the appliance. Make use of the different zones when placing food in the appliance.

This appliance has automatic dynamic cooling, which helps to keep an even temperature when the fan is running, making the difference between the various zones less pronounced.

- pre-packed vegetables and other fresh food with a label stating it should be kept at a temperature of approx. 4 °C.

Warmest area

The warmest area is in the top section of the door. Use this for storing butter and cheese.

Coldest area

The coldest area in the refrigerator is directly above the MasterFresh zone. However, the MasterFresh zone compartments are even colder.

Use these areas in the refrigerator and in the MasterFresh zone for all delicate and highly perishable food, e.g.

- fish, meat, poultry,
- sausage products, ready meals,
- dishes or baked goods containing eggs or cream,
- fresh dough, cake mixtures, pizza or quiche dough,
- soft cheese and other dairy products,

Storing food in the refrigerator section

Do not store explosive materials in the appliance or any products containing propellants (e.g. spray cans).

Danger of explosion.

If storing alcohol with a high percentage proof, make sure it is tightly closed, and store upright.

If storing food which contains a lot of fat or oil in the appliance or the appliance door, make sure that it does not come into contact with plastic components as this could cause stress cracks or break the plastic.

Do not place food in front of the vents at the back of the appliance as the food could freeze and in some circumstances could burst (e.g. bottles).

Food must not touch the back wall of the appliance, as it may freeze to the back wall.

Ensure that when placing food in the refrigerator, a gap of at least 35 mm is maintained under the ceiling of the appliance to enable the air to circulate freely.

Only use the area to the front of the refrigerator zone floor to place food temporarily. Do not leave it there, as when you shut the door it may get pushed over, causing spillages.

To allow air to circulate efficiently, do not pack food too closely together in the refrigerator. Make sure the vents at the back of the appliance are not covered, as this is essential for keeping the appliance cool.

Storing food in the refrigerator section

Food which is not suitable for storing in a refrigerator

Not all food is suitable for storing in a refrigerator at temperatures below 5 °C, as some food is sensitive to cold. Cucumbers, for example, become glassy, aubergines bitter and potatoes sweet. Tomatoes and oranges lose their aroma, and the peel on citrus fruits hardens.

Food which does not tolerate cold temperatures includes:

- Pineapples, avocados, bananas, pomegranates, mangos, melons, papayas, passion fruit, citrus fruit (such as lemons, oranges, mandarins, grapefruit),
- Fruit which is not yet ripe,
- Aubergines/egg plant, cucumber, potatoes, peppers/capsicum, tomatoes, courgettes/zucchini,
- Some hard cheeses, e.g. Parmesan.

When shopping for food

The freshness of food when first placed in the appliance is an important factor in determining how long it stays fresh, and how long it can be kept in the appliance. Always observe the use-by date and the recommended storage temperature.

Time out of the refrigerator, e.g. during transportation, should be kept to a minimum. For example, do not allow food to stay in a hot car for too long.

Tip: Take a cool bag with you when shopping and on return, place food into the appliance immediately.

Storing food correctly

Food should generally be stored covered or packaged in the refrigerator (there are some exceptions to this rule in the MasterFresh zone). This will prevent food smells from affecting other food, food from drying out, and also any cross-contamination of bacteria. This is particularly important for protein-based food such as meat or fish.

The growth of bacteria, such as salmonella, can be avoided by setting the correct temperature and maintaining good standards of hygiene.

Storing food in the MasterFresh zone

Food is stored at a lower temperature in the MasterFresh zone than in the refrigerator section. The humidity in the MasterFresh zone compartments can also be regulated to suit the food being stored, providing ideal storage conditions and ensuring that food stays fresh considerably longer while retaining both flavour and vitamins.

Storage temperature

The optimum storage temperature for fresh food which is not sensitive to cold is 0 - 3 °C. This is the temperature range which is automatically maintained in the MasterFresh zone. Food can be stored there at this temperature without loss of freshness for considerably longer than in a standard refrigerator, as the deterioration process is decelerated at this temperature.

Remember that the fresher the food when placed in the appliance, the longer it will stay fresh.

Humidity level

The humidity level in the MasterFresh compartment will depend on

- the moisture content of the food being stored and
- the quantity of food being stored.

The humidity of food being stored is retained in the MasterFresh compartment. The closer the storage humidity is to the humidity content of the food, the crisper and fresher the food remains over a longer period, as the water content of the food is largely retained.

Storing food in the MasterFresh zone

The MasterFresh drawer is divided into two compartments:



- Touch the sensor to select the MasterFresh compartment you want to use.

The sensor for the MasterFresh compartment selected is now highlighted in yellow and the symbols for the types of food you wish to store now appear:



- Left: Food which require high humidity, such as vegetables and fruit
- Right: Food which require low humidity, such as meat, fish and dairy produce.

- Touch the sensor for the types of food you wish to store in the MasterFresh compartment selected.

Storing food in the MasterFresh zone

- You can deselect the type of food by touching the relevant sensor again.

You cannot store food that **likes** high humidity in a drawer with food that prefers a dry atmosphere. However, you can store different food from the same humidity/dry group together.

- The food can now be placed in the MasterFresh zone.

Food that prefers a higher humidity include:

- Freshly picked vegetables, lettuce, herbs, mushrooms, cabbages and fruit.

TIP

The level of humidity in the MasterFresh drawer depends on the moisture content and quantity of the food being stored.

For **smaller quantities** it is best to store food **wrapped**.

Food that prefers a dry atmosphere include:

- fresh fish, shellfish, meat, poultry, sausages, dairy products and speciality salads.

Please note that food rich in protein deteriorates faster than others.

Shellfish, for example, deteriorates faster than fish, and fish deteriorates faster than meat.

Always keep these these types of food **covered or wrapped**.

Exception: Meat. The surface of the meat dries out slightly, helping to prevent the growth of bacteria, which results in the meat lasting longer. To prevent the risk of bacterial cross-contamination and meat deteriorating, do not let one type of meat come into direct contact with another type.

Take food out of the MasterFresh zone approx. 30 - 60 minutes before using it. The aroma and taste do not fully develop until the food has reached room temperature.

Please note: The function of the MasterFresh compartments is reduced when the dividing panel is not in place.

Storing food in the MasterFresh zone

The following tips may help if you find that food you have stored does not keep well (e.g. food becomes limp or wilts after only being stored for a short time):

- Only use the appliance for storing fresh food. The condition of the food when it is first placed in the appliance is an important factor in determining how long it stays fresh.
- Clean the MasterFresh zone before placing food in it.
- Allow very moist food to drain before storing it.
- Do not store food which is sensitive to cold in the MasterFresh zone (see "Food which is not suitable for storing in a refrigerator")
- Bear in mind that not all types of food can be stored together (see ""Food which is not suitable for storing in a refrigerator"..).
- Organise the food to be stored into groups requiring lower or higher humidity.
- Store food unwrapped in the high humidity MasterFresh compartment. High humidity in the MasterFresh zone can only be achieved by storing food which contains moisture in it.
If the humidity is not high enough, because, for example, too little food has been stored in the compartment, you can use a wet sponge to increase the humidity.
- If you think that the temperature in the MasterFresh zone is too high or too low, try regulating it by altering the temperature of the refrigerator section by 1 to 2 °C.
The temperature must be increased if ice crystals start to form on the floor of the MasterFresh zone as otherwise the cold temperature will damage the food.
- If a lot of water has gathered on the base of the MasterFresh zone, dry the base with a towel. Drain food before storage or place a rack on the floor of the MasterFresh zone and place the food on the rack so that the moisture can drip down.

Arranging the interior fittings

Moving the shelves

The shelves can be adjusted according to the height of the food.

- Hold the shelf on both sides and raise it slightly so that it can be lifted over the catches at the back.
- Pull the shelf forwards.
- Place the shelf at the required level, ensuring that it has engaged in the catches at the back.
- Make sure that the shelf is on straight.

Floating deli drawer

The drawer can be positioned to the right or left by sliding it to the required position.

It can also be placed, together with its holder, under a different shelf - or this can be achieved by simply swapping the shelves over.

The floating drawer can be removed completely for cleaning purposes:

- To do this, pull the drawer out over the drawer stops.

To replace it

- Push the drawer straight into runners.

The MasterFresh drawer

The MasterFresh drawer sits on telescopic runners, and can be fully pulled out for loading and unloading.

For cleaning, the MasterFresh drawer can be removed completely.

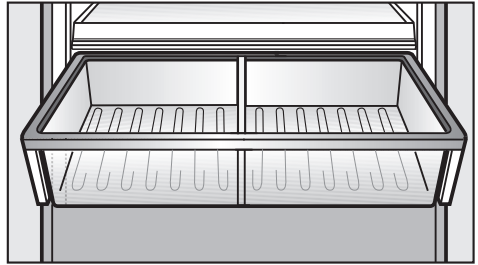

- Pull the MasterFresh drawer out as far it will go.

To prevent children from hurting themselves, there is a pin on the door opening side which needs to be turned to a horizontal position in order to remove the drawer.

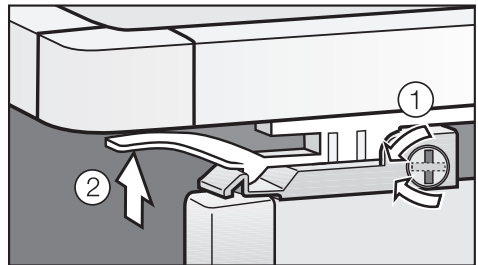

- Use a screwdriver or similar to turn the pin so that the slot in its head is horizontal ①.
- Raise the snap fittings on both sides ②, and lift the MasterFresh drawer up and out.

Arranging the interior fittings

To avoid damaging the telescopic runners, make sure that they are pushed back into the appliance.

The dividing panel in the MasterFresh drawer can be removed for cleaning.

- Take the MasterFresh drawer out of the appliance completely.
- Pull the dividing panel in the MasterFresh drawer up and out to remove it.
- After cleaning, slide the dividing panel back into the drawer.

Please note: The MasterFresh zone does not work as efficiently without the dividing panel in place.

To replace the drawer

- Pull the telescopic runners out as far as they will go.
- Place the MasterFresh drawer on the runners so that it engages at the back and front.
- Turn the slot on the pin to its vertical position.
- Push the MasterFresh drawer all the way back into the appliance.

Adjusting the door shelves/bottle shelf

The door shelves can be moved when loading or unloading and for cleaning or they can be removed completely.

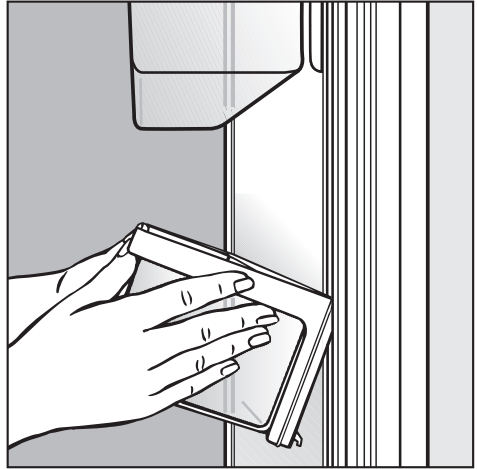

- Hold the door shelf by its frame with both hands, raise it a little and then tip it forwards slightly.
- Slide the shelf in this angled position up or down in the side runners as required, and then lower it into its new position.
- Make sure that the shelf is straight.

To remove the door shelf altogether,

- Slide it up the side runners to the very top, then lift it out.

To replace the door shelf

- Engage it in the runners at the top, and lower to the position required.

Arranging the interior fittings

For the purposes of loading and unloading or to clean, the containers can be removed from their holders completely.

To remove the container in the top door shelf from its holder,

- Undo the screws on the shelf and remove the cover.
- Unhinge the flap from its holder.
- Lift the container up and out.

To remove the shelf above the MasterFresh drawer

- Remove the trim at the back, push back the glass shelf slightly, then lift it carefully up and out.

Small freezer basket

The small basket can be removed for cleaning.

- Pull the small basket out as far it will go.

To prevent children from hurting themselves, there is a pin on the door opening side which needs to be turned to a horizontal position in order to remove the basket.

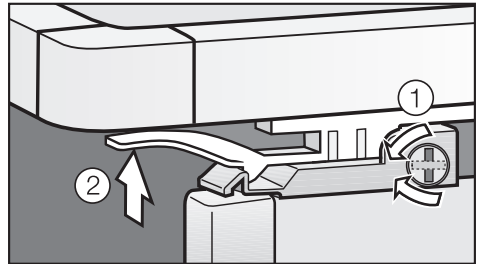

- Use a screwdriver or similar to turn the pin so that the slot in the head is horizontal ①.
- Raise the snap fittings on both sides ②, and lift the freezer basket up and out.

To replace the small freezer basket

- Pull the telescopic runners out as far as they will go.
- Place the freezer basket on the runners so that it engages at the back and front.
- Turn the slot on the pin to its vertical position.
- Push the freezer basket back in.

Arranging the interior fittings

Large freezer basket with dividing panel

The large basket can be removed for cleaning.

- Close the door to the refrigerator section.
- Open the freezer drawer.
- Lift the large freezer basket up and out to remove it.

The dividing panel in the large freezer basket can be removed for cleaning.

The dividing panel is held in place by fittings in the freezer basket.

To loosen the fittings,

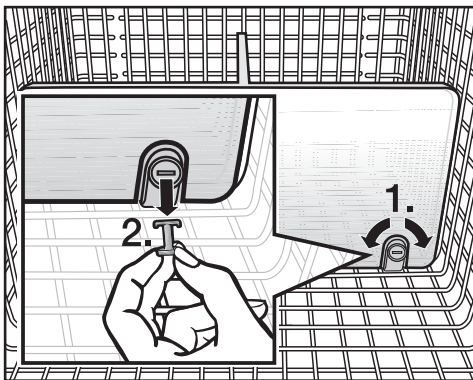

- Use a screwdriver or similar to turn the slots in the pegs to a horizontal position ①.
- Remove the pegs from the fittings ②.
- Pull the dividing panel upwards to remove it.

To replace the dividing panel

- Place the fittings in an upright position, and locate the dividing panel in the fittings so that you hear it click into place.
- Replace the pegs in the fittings, and use a screwdriver or similar to turn the slots in the pegs into a vertical position.

To replace the freezer basket

- Position the basket by locating the pegs into their holes from above.

Maximum freezing capacity

To ensure that fresh food placed in the freezer freezes through to the core as quickly as possible, the maximum freezing capacity must not be exceeded. The maximum freezing capacity for freezing within a 24-hour period is given on the data plate: "Freezing capacitykg/24 hrs".

The maximum freezing capacity given on the data plate has been calculated according to DIN EN ISO 15502 Standard.

Freezing fresh food

Fresh food should be frozen as quickly as possible. This way the nutritional value of the food, its vitamin content, appearance and taste are not impaired.

Food which takes a long time to freeze will lose more water from its cells, which then shrink.

During the defrosting process, only some of this water is reabsorbed by the cells; the rest collects around the food.

If food is frozen quickly, the cells have less time to lose moisture, so they shrink less. As there is not so much moisture loss, it is easier for the food to reabsorb it during the defrosting process, and very little water collects around the defrosted food.

Storing frozen food

When buying frozen food to store in your freezer section, check

- that the packaging is not damaged,
 - the use-by date,
 - the temperature at which the frozen food is being stored in the shop. The length of time it can be kept is reduced if it has been stored at a temperature warmer than -18 °C.
- Buy frozen food once you have finished the rest of your shopping, and wrap it in newspaper or use a cool bag or cool box to transport it.
 - Store it in the freezer as soon as possible.

Never re-freeze partially or fully defrosted food. Consume defrosted food as soon as possible as it will lose its nutritional value and spoil if left for too long. Defrosted food may only be re-frozen after it has been cooked.

Freezing and storing food

Home freezing

Only freeze fresh food which is in a good condition.

Hints on home freezing

- The following types of food **are suitable** for freezing:
Fresh meat, poultry, game, fish, vegetables, herbs, fresh fruit, dairy products, pastry, leftovers, egg yolks, egg whites and a range of pre-cooked meals.
- The following types of food **are not suitable** for freezing:
Grapes, lettuce, radishes, sour cream, mayonnaise, eggs in their shells, onions, whole raw apples and pears.
- To retain colour, taste and vitamin C, vegetables should be blanched after they have been trimmed and washed.
To blanch: bring a large saucepan of water to the boil, immerse the vegetables in the fast boiling water for 2-3 minutes, depending on variety. Remove, and plunge into ice-cold water to cool quickly. Drain and pack ready for freezing.
- Lean meat freezes better than fatty meat, and can be stored for considerably longer.
- To prevent chops, steaks, cutlets or rolled meat from freezing together in solid blocks when packed, separate with a sheet of plastic freezer film.

- Do not season fresh foods or blanched vegetables before freezing. Only season cooked food lightly before freezing, but care should be taken as the taste of some spices alters when frozen.
- Do not place hot food or drinks in the freezer. This causes already frozen food to thaw, and increases the energy consumption considerably. Allow hot food and drinks to cool down before placing them in the freezer.

Packing

- Freeze food in portions.
Unsuitable packing material
 - wrapping paper
 - grease-proof paper
 - cellophane
 - bin bags
 - plastic carrier bags
 - Suitable packing material**
 - plastic freezer film
 - freezer bags
 - aluminium foil
 - freezer containers
 - Expel as much air as possible from bags etc. before sealing them, to prevent freezer-burn on food.
 - Close the packaging tightly with
 - rubber bands
 - plastic clips
 - string or bag ties
 - freezer tape.
- Freezer bags may also be sealed using home heat sealing kits.
- Make a note of the contents and the date of freezing on the packaging.

Before placing food in the freezer

- When freezing more than 2 kg of fresh food, switch on the Super freeze function for some time before placing the food in the freezer (see "Super freeze").
This also helps to prevent food that is already in the freezer from starting to defrost.

Placing food in the freezer

Food to be frozen can be placed anywhere in the freezer.

Place large quantities of food in the large freezer basket.

Please follow the guidelines in the table below regarding recommended weights for the baskets:

	Small basket	Large basket
KF 1801 Vi, KF 1811 Vi	14 kg	33 kg
KF 1901 Vi, KF 1911 Vi	19 kg	43 kg

- Place the food flat in the bottom of the basket so that it freezes through to the core as quickly as possible.
- Make sure that the packaging and containers are dry to prevent them sticking together when frozen.

When freezing, make sure that food already frozen does not come into contact with fresh food being frozen as this could cause the frozen food to begin to defrost.

Defrosting

Frozen food can be defrosted in different ways:

- in a microwave oven,
- in an oven using the "Fan" or "Defrost" setting,
- at room temperature,
- in the refrigerator (the cold given off by the frozen food helps to keep the other food cold),
- in a steam oven.

Poultry It is particularly important to observe food hygiene rules when defrosting poultry. Do not use the liquid from defrosted poultry. Pour it away and wash the container it was in, the sink and your hands. Danger of salmonella poisoning.

Fruit should be defrosted at room temperature in its packaging, or in a covered bowl.

Most vegetables can be cooked while still frozen. Just put straight into boiling water or hot fat. The cooking time is slightly less than that of fresh vegetables due to changes in the cell structure.

Never re-freeze partially or fully defrosted food. Consume defrosted food as soon as possible as it will lose its nutritional value and spoil if left for too long. Defrosted food may only be re-frozen after it has been cooked.

Freezing and storing food

Cooling drinks

To cool drinks quickly, place them in the refrigerator zone, and switch on the Super cool function. If bottles are, however, placed in the freezer zone for rapid cooling, make sure they are not left in for more than one hour, as they could burst.

For the automatic ice cube maker to operate it must be connected to the mains water supply (see "Mains water connection").

Switching on the ice cube maker

- Make sure that the ice cube container is correctly located underneath the ice cube maker.

The ice cube container must be completely shut for ice cubes to be produced.

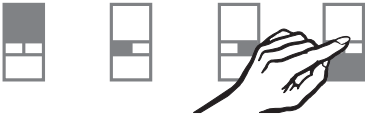

- Touch the sensor for the freezer zone so that it is highlighted in yellow.



- Touch the On/Off sensor for the ice cube maker so that it is highlighted in yellow.

Once the freezer has cooled down to its set temperature, the ice cube maker will fill with water.

When the water has frozen, the ice cubes will drop out of the ice cube maker into the ice cube container.

The ice cube maker can make up to 140 ice cubes in 24 hours.

The amount of ice cubes which the appliance makes depends on the temperature in the freezer zone. The

lower the temperature, the more ice cubes are produced.

After the appliance is switched on for the first time it can take up to 10 hours for the first ice cubes to drop out of the ice cube maker and collect in the container.

Ice cube production is halted automatically when the ice cube container is full.

Do not place bottles or other items in the ice cube maker to chill them quickly. The ice cube maker could become blocked and, as a result, be damaged.

Do not use the first three containers full of ice cubes, as the water will have been used to rinse through the water pipework. This also applies when making ice cubes for the first time after not having used the appliance for a while.

Making ice cubes

Switching off the ice cube maker

The appliance must be disconnected from the mains water supply a few hours before the ice cube maker is switched off.

The ice cube maker can be switched off independently of the freezer if you do not want the appliance to make any ice cubes.



- Touch the On/Off sensor for the ice cube maker so that it is highlighted in white.

Refrigerator zone and MasterFresh zone

Condensate and frost can build up on the back wall of the refrigerator zone and the MasterFresh zone whilst in use. You do not need to remove this, as it will defrost and evaporate automatically with the warmth generated by the appliance.

Freezer zone

This appliance is equipped with a "Frost free" system. The freezer zone defrosts automatically.

The moisture generated in the appliance collects on the condenser and is automatically defrosted and dissipated by the condenser from time to time.

This automatic defrosting system enables the freezer zone to remain permanently ice-free, however, the food stored in the freezer zone will not defrost.

Cleaning and care

Make sure that water cannot get into the electronic unit or into the lighting.

Do not use steam cleaning apparatus to clean the appliance. Steam could reach electrical components and cause a short circuit.

The data plate located inside the appliance must not be removed. It contains information which is required in the event of a service call.

To avoid damaging the surface of your appliance, do not use:

- cleaning agents containing soda, ammonia, acids or chlorides,
- cleaning agents containing descaling agents,
- abrasive cleaning agents, e.g. powder cleaners and cream cleaners,
- solvent-based cleaning agents,
- stainless steel cleaning agents,
- dishwasher cleaner,
- oven sprays,
- glass cleaning agents,
- hard, abrasive sponges and brushes, e.g. pot scourers,
- melamine eraser blocks,
- sharp metal scrapers.

Before cleaning



- Switch the appliance off completely by pressing the On/Off rocker switch on the right side underneath the control panel.
- Disconnect the appliance from the mains.
- Take any food out of the appliance and store it in a cool place.
- Take out any removable parts, e.g. shelves, for cleaning.
- Remove the containers from their stainless steel frames in order to clean the door shelves.

Cleaning the interior and accessories

Use lukewarm water with a little washing-up liquid.

Wash all accessories and drawers by hand only. Do not wash in a dishwasher.

- Clean the appliance at least once a month.
- After cleaning, wipe the interior and accessories with a damp cloth and dry with a soft cloth. Leave the door and drawer open to air the appliance for a short while.

Aluminium frames

The frames on the shelves inside the appliance and in the door are made from aluminium.

Aluminium is affected by the way that light falls on it, by the surrounding environment and by the angle you observe it from.

It is also susceptible to scratching.

The aluminium frames may suffer discolouration or damage if soiling is left on for too long. Remove any soiling immediately.

Ice cube container

The ice cube container sits on telescopic runners, and can be fully extended for loading and unloading.

For cleaning, the ice cube container can be removed completely.

- Pull the ice cube container out as far as it will go.

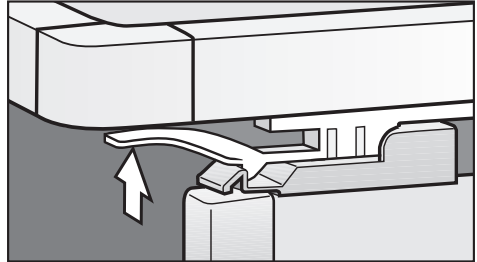

- Raise the snap fittings on both sides and lift the ice cube container out.

To avoid damaging the telescopic runners, make sure that they are pushed back into the appliance .

To replace the ice cube container

- Pull the telescopic runners out as far as they will go.
- Place the ice cube container on the rails so that it engages at the back and front.
- Push the ice cube container back in.

Cleaning and care

Humidity filters

The two special humidity filters above the MasterFresh compartments have to be removed for cleaning.

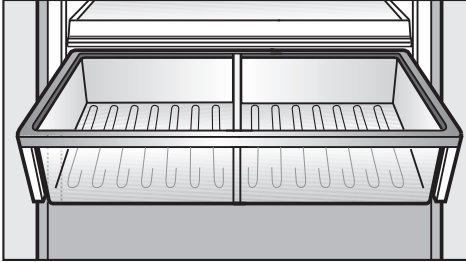

- Pull out the MasterFresh drawer and remove it.

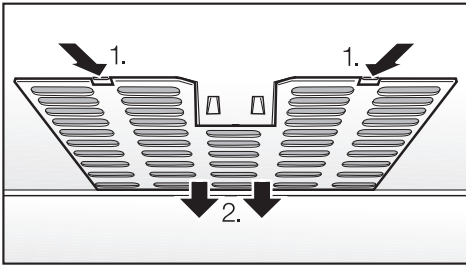

- Release the filter cover ①, then lower it together with the filter mat and remove ②.

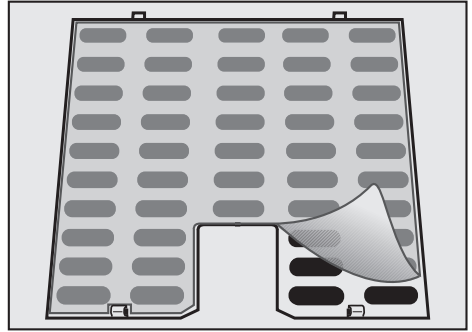

- Take off the filter mat.
- Clean the filter mat in lukewarm water without any detergent.

Do not wash the filter mats in a dishwasher or washing machine.

- Leave the filter mat to dry.
- Replace the filter mat in the filter cover.
- Replace the filter cover, engaging it first at the back and then at the front.
- Replace the MasterFresh drawer in the appliance.

Ventilation gaps

- The ventilation gaps should be cleaned on a regular basis with a brush or vacuum cleaner. A build-up of dust will increase the energy consumption of the appliance.

Door seals

Do not use any grease or oil on the door/drawer seals as these will cause the seals to deteriorate and become porous over time.

The seals should be cleaned regularly with clean water, and then wiped dry with a soft cloth.

After cleaning

- Replace all shelves and accessories in the refrigerator zone.
- Reconnect to the mains and switch the appliance back on.
- Place food back in the refrigerator and close the door.
- Switch on the Super freeze function so that the freezer can cool down quickly.
- Once the freezer zone has reached the required temperature, place the food back in the freezer drawers and shut them.
- Switch off the Super freeze function as soon as the temperature in the freezer is a constant -18 °C or colder.

Problem solving guide

Repairs to electrical appliances should only be carried out by a suitably qualified and competent person in strict accordance with current local and national safety regulations. Repairs and other work by unqualified persons could be dangerous. The manufacturer cannot be held liable for unauthorised work.

What to do if . . .

. . . the appliance does not get cold.

- Check whether the appliance has been switched on. If it is switched on, the access sensor will light up in the display.
- Check that the plug is correctly inserted into the socket and switched on.
- Check that the fuse is not defective and the mains fuse has not tripped. If it has contact a qualified electrician or the Miele Service department.
- Check the temperature settings.

. . . the temperature in the refrigerator or freezer zone is too low.

- Increase the temperature.
- Switch off the Super freeze or Super cool functions if these are switched on.
- Check that the door/drawer has been closed properly.

- Has a large amount of fresh food been frozen at the same time? This makes the compressor run for longer, causing the temperature in the refrigerator to fall automatically.

. . . the freezer zone will not open because it has been opened and closed too many times in succession.

- This is not a fault. The suction caused by opening and closing the freezer is preventing it from opening. Wait a few minutes and then try again. It should now open without force.

. . . the compressor is switching in too frequently and for too long.

- Check whether the ventilation gaps in the plinth have been covered over or become too dusty.
- The refrigerator door or the freezer drawer has been opened too frequently, or a large amount of fresh food has been put in at once for freezing.
- Check that the door/drawer has been closed properly.

. . . the compressor runs continuously.

To save energy, the compressor runs at a lower speed, but for longer, when less cooling is required.

... The temperature display for the freezer shows -18 °C, even though I have selected a higher temperature?

- This is not a fault. If the ice maker is switched on and the room temperature is less than +18 °C, the temperature is automatically set to -18 °C.
This is to ensure trouble-free functioning of the ice cube maker.

... the frozen food is thawing because the freezer zone is too warm.

- Is the room temperature lower than the ambient temperature for which the appliance is designed?

If so, increase the temperature of the room.

Operating in a room which is too cold will cause the compressor to switch off for too long, causing the freezer to become too warm.

... food has frozen together.

- Use a blunt instrument, e.g. a spoon handle or plastic scraper, to prise it apart carefully.

... the alarm sounds.

Has the door/drawer been open for longer than 5 minutes?

- Close the door or the drawer.

... the alarm sounds and the sensor for switching off the temperature or door alarm lights up or is flashing.

- The door/drawer is open, or
- The temperature in one of the zones has risen significantly because
 - too much warm air from the room has entered the appliance,
 - large quantities of food have recently been placed in the freezer,
 - there has been a power cut.

The alarm will stop and the sensor for switching the temperature or door alarm off will go out as soon as the temperature is at the correct level.

If the temperature rises in the freezer, the temperature display will show the highest temperature that was reached during the time the temperature in the freezer rose.

Check the condition of the food in the freezer. If it has defrosted or started to defrost, check that it is still safe to use and if so use it as soon as possible. Defrosted food may only be re-frozen after it has been cooked.

... the reminder to change the water filter indicator lights up red.

The water filter will soon need to be changed.

- You can order a replacement filter from your Miele dealer or the Miele Spare Parts Department.

Problem solving guide

... the reminder to change the water filter indicator flashes red.

- Change the water filter.

... you cannot switch the ice cube maker on.

- Check whether the appliance is connected to the electricity supply.
- Check whether the freezer zone has been selected. The sensor for this must be highlighted in yellow.

... the ice cube maker is not producing any ice cubes.

- Check whether the appliance has been switched on.
- Check whether the ice cube maker has been switched on
- Check whether the appliance is correctly connected to the mains water supply.
- Was the water inlet pipe purged of air by a qualified and competent person before the appliance was used for the first time?
- Check whether the stopcock is open.
- Check that the ice cube container is positioned correctly.
- Check that the temperature in the freezer zone is low enough.
- Check whether there is sufficient water pressure. The water pressure (flow rate) must be between 1.7 and 5.5 bar.
- Check that the correct valve was installed; an incorrect valve may cause a drop in water pressure.

Remember it can take up to 10 hours to produce the first ice cubes.

... the ice cube maker is only producing small ice cubes.

- Are other appliances that are connected to the mains water supply being used at the same time? Avoid using the dishwasher, washing machine etc at the same time.
- Check whether the water filter needs to be changed.
- Check whether there is sufficient water pressure. The water pressure (flow rate) must be between 1.7 and 5.5 bar.
- Check that the correct valve was installed; an incorrect valve may cause a drop in water pressure.

Remember it can take up to 10 hours to produce the first ice cubes.

... the ice cubes taste or smell odd.

- How often do you use the ice cube maker?
If you do not use it very often, ice cubes that are stored for a long period can absorb the taste and smell of other items.
- Are you storing unwrapped food in the freezer section?
Ice can absorb the taste and smell of unwrapped food.
- Check that the ice cube container is clean and wash it if necessary.

... the ice cube maker is producing too few or misshapen ice cubes.

- Check whether there is sufficient water pressure. The water pressure (flow rate) must be between 1.7 and 5.5 bar.
- Check that the temperature in the freezer zone is low enough.
- Change the water filter.

... water is pouring out of the appliance.

- Close the stopcock immediately.
- Check whether the water pipework inside the appliance is damaged. Call the Service Department.
- Check whether there is sufficient water pressure.
- Check whether the correct valve was fitted.

... "_F" and "i2?" appear alternately in the temperature display.

The ice cube maker is not connected to the mains water supply.

- Check whether the appliance is correctly connected to the mains water supply.
- Check whether the stopcock is open.

... Another fault message with "_F" appears in the temperature display.

There is a fault. Call the Service Department.

... the interior lighting is not working.

Has the appliance door been left open for too long? To avoid overheating, the lighting switches itself off automatically after approx. 5 minutes if the door is left open. It will come on again after it has cooled down sufficiently.

If it does not come on when the door is opened briefly, then the lighting is defective.

- Switch the appliance off by pressing the On/Off rocker switch to the right hand side underneath the control panel.
- Disconnect the appliance from the mains electricity supply.

Top lighting

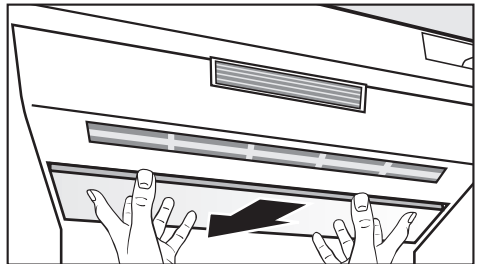

- Hold the lamp cover at the front with both hands and push it back.
- Then lift the lamp cover forwards to remove.

Do not touch halogen lamps with your bare fingers.
Use a soft cloth when changing a halogen lamp.

Problem solving guide

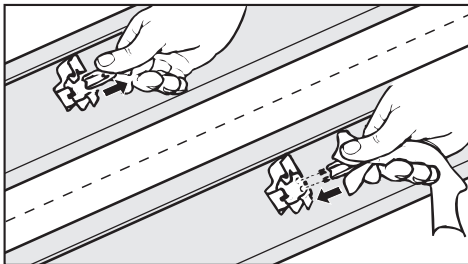

- Pull the defective halogen lamp out.
- Fit the new lamp into the holder.
The following type of halogen lamp is required:
20 W/12 V/GY 6.35 cap.
- Engage the lamp cover at the back, then pull it forward and click it into place at the front.

Side lighting

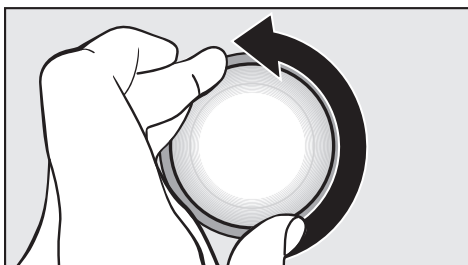

- Turn the lamp cover anti-clockwise to remove it.

Do not touch halogen lamps with your bare fingers.
Use a soft cloth when changing a halogen lamp.

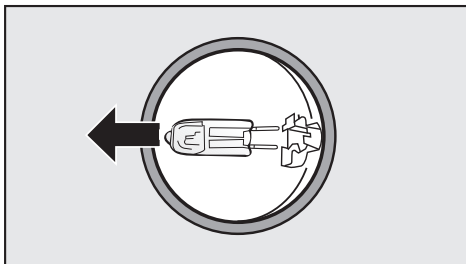

- Pull the defective halogen lamp out.
- Fit the new lamp into the holder.
The following type of halogen lamp is required:
5 W / 12 V / G 4 cap.
- Replace the lamp cover, turning it clockwise as far as it will go.
- Reconnect the appliance to the electricity supply and switch it on.

If you still cannot remedy the fault having followed these suggestions, please contact the Miele Service Department.

To prevent unnecessary loss of temperature, it is advisable not to open the door/drawer while waiting for the appliance to be serviced.

The appliance is supplied with a standard water filter that filters mains water for making ice cubes.

You can replace this with an active charcoal filter which improves the taste and smell of the ice cubes by removing chlorine and other substances from the mains water.

Replacement water filters (standard and active charcoal) are available from Miele.

To ensure the quality of the ice cubes remains high, it is essential to change the water filter regularly.

Please note:

- All ice cubes that are produced in the 24 hours after you have changed the water filter should be discarded.
- If you have not used the appliance or the ice cube maker much in the last few weeks, or if the ice cubes smell unpleasant, fit a new water filter.

Reminder to change the water filter

Depending on the amount of ice cubes being made, the water filter will need to be changed approx. every six months.



- When the reminder to change the water filter **lights up** red, this indicates that the filter will soon need to be changed.
- Make sure that you have a spare water filter ready to fit.

Replacement water filters (standard and active charcoal) are available from Miele.

- When the reminder to change the water filter **flashes** red, this indicates that the filter needs to be changed now.

Water filter

To change the water filter

Air in the system can cause water to gush out and the filter to spring out when it is removed. Take great care, therefore, when changing the filter.

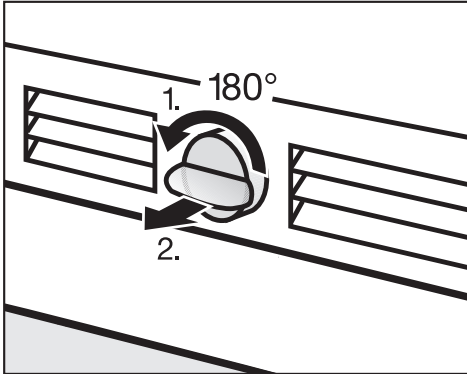

- Press the cap in and turn it 180° in an anti-clockwise direction (1).
- Remove the old filter cartridge (2).

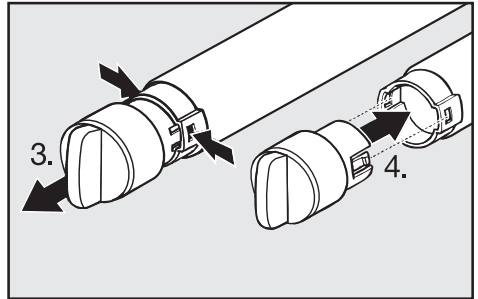

- Remove the cap from the old filter cartridge (3).
- Take the new filter cartridge from its packaging, and remove the protective cover.
- Fit the cap on the new filter cartridge (4).

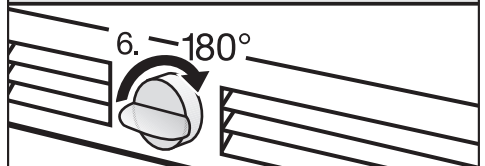
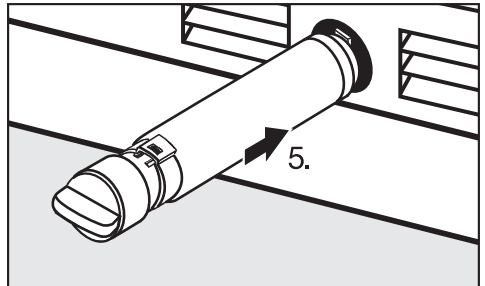

- Push the filter cartridge back into the opening, ensuring that it is straight (5).
- Turn the cap 180° in a clockwise direction until it is horizontal (6).



- After the filter has been changed, the reminder to change the filter will continue to flash in the display. Confirm that the filter has been changed.

To confirm that the water filter has been changed



- Place a finger on the water filter change display and leave it there.



- Place another finger on the access sensor (do not release the water filter change display) and keep both sensors covered for approx. 5 seconds, until a tone sounds.

The water filter change has now been confirmed and the reminder for the next filter change activated.

The reminder to change the filter will now go out in the display.

- Close the door.

All ice cubes that are produced in the 24 hours after you have changed the water filter should be discarded.

Using an external water filter

If an external water filter is installed in the household, please leave the standard (bypass) filter in the appliance.

If you use an external water filter and therefore wish to deactivate the reminder to change the water filter, please contact the Miele Service Department.

Noises

Normal noises	What causes them
Brrrrr ...	A humming noise is made by the motor (compressor). This noise can get louder for brief periods when the motor switches on.
Blubb, blubb ...	A gurgling noise can be heard when coolant is circulating through the pipes.
Click ...	Clicking sounds are made when the thermostat switches the motor on and off.
Sssrrrrr ...	On multi-zone and frost-free appliances you can sometimes just hear the sound of the fan inside the appliance.
	On appliances with a water container you can sometimes hear the sound of water being pumped out of the water container.
Crack ...	A cracking sound can be heard when materials expand inside the appliance.

Remember that the noise of the compressor and the coolant circulating in the system is unavoidable.

Noises that you can easily rectify	Possible cause	Remedy
Rattling, vibrating	The appliance is uneven.	Realign the appliance using a spirit level, by raising or lowering the screw feet underneath the appliance.
	The appliance is touching another appliance or piece of furniture.	Move it away.
	Drawers, baskets or shelves are unstable or sticking.	Check all removable items and refit them correctly.
	Bottles or containers are touching each other.	Separate them.
	The transport cable clips are hanging loose at the back of the appliance.	Remove the cable clips.

In the event of any faults which you cannot remedy yourself, or if the appliance is under guarantee, please contact

– your Miele Dealer

or

– the Miele Service Department.

See the end of this booklet for contact details.

When contacting your Dealer or Miele, please quote the model and serial number of your appliance.

This information is given on the data plate inside the appliance.

Please note that telephone calls may be monitored and recorded for training purposes.

N.B. A call-out charge will be applied to service visits where the problem could have been resolved as described in these instructions.

Guarantee

For further information on the appliance guarantee specific to your country please contact Miele. See the end of this booklet for contact details.

In the U.K. your appliance is guaranteed for 2 years from the date of purchase. However, you must activate your cover by calling 0845 365 6640 or registering online at www.miele.co.uk.

Note for test institutes

Testing must be carried out in accordance with the **relevant Norms and Directives**.

In addition, the following manufacturer's instructions should be observed when preparing and carrying out tests:

- **Loading plans,**
- Instructions in the **Operating and installation instructions.**

The MasterFresh compartment satisfies the requirements of a chill compartment to EN ISO 15502.

Notes on connecting to the mains water supply

Connection to the mains water supply should only be carried out by a qualified and competent person.

Disconnect the appliance from the mains electricity supply before connecting it to the mains water supply.

Close the stopcock before connecting the water intake hose to the appliance.

The water quality must conform to the requirements for drinking water in the country the appliance is being installed in.

The connection to the household water supply must conform to the requirements for the country the appliance is being installed in. All appliances, and any devices used for supplying water to the appliance, must conform to the appropriate national regulations.

- This appliance meets the requirements of IEC 61770 and EN 61770.
- The water pressure (flow rate) must be between 1.7 (170 000 Pa) and 5.5 (550 000 Pa) bar.

Warning

Water pressure which is too high can cause damage to the appliance.

Install a pressure regulator if the water pressure in the pipes exceeds 5.5 bar.

- The stainless steel hose supplied is 3 m long and must not be lengthened.

A faulty stainless steel hose must only be replaced by a genuine Miele replacement hose (available from Miele). Make sure that the water hose is suitable for food use.

- A stopcock must be provided between the stainless steel hose and the household water supply to ensure that the water supply can be disconnected if necessary.

Mains water connection

The stopcock should be easily accessible after the appliance has been built in.

Preparing for plumbing the appliance into the mains water supply

Plumbing connections must be correctly in place before the appliance is built in.

Before making plumbing connections, ensure that the appliance is disconnected from the mains electrical supply.

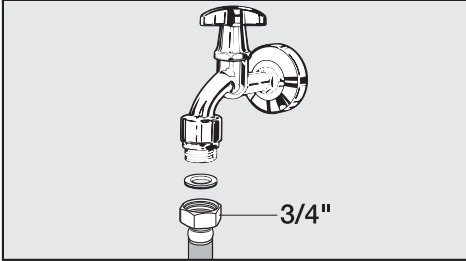

Connection to the mains water supply should incorporate a mains stopcock with $\frac{3}{4}$ " thread.

- Connect the stainless steel hose to the stopcock.
- Ensure that it is screwed into position correctly.

The appliance is only suitable for connection to a cold water supply, which

- is connected directly to the fresh water supply, to guarantee circulation of water throughout the system.

Avoid laying the water hose in such a way that water can collect in it, as this can affect the taste of the water or the ice cubes.

- sustains operating pressure.
- complies with hygiene regulations.

Mains water connection

Before using the appliance for the first time the water inlet pipe should be purged of air by a qualified and competent person.

- To do so the stainless steel hose should be filled as far as possible with water before being connected to the appliance.
- Mop up any spillages with a cloth.

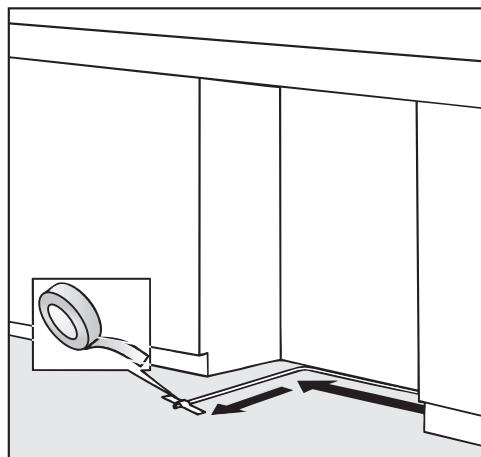

- Lay the stainless steel hose in the building-in niche as shown, and secure to the floor with adhesive tape. This ensures that the hose cannot slip or get caught when the appliance is pushed back into the niche.
- The appliance can now be installed in the niche (see "Installation").

Appliances with an opening for feeding the hose through:

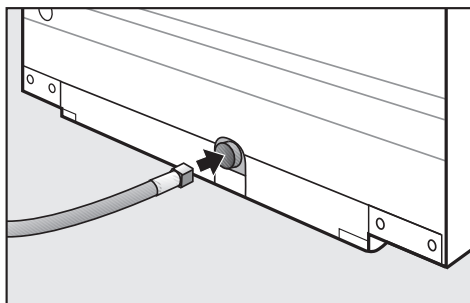

- Position the appliance in front of the building-in niche and feed the stainless steel hose through the opening at the back of the appliance. At this stage the building-in niche should be ready for the appliance to be pushed into the niche (see "Installation").
- Proceed with building in the appliance.

Mains water connection

Fitting the stainless steel hose to the appliance

When fitting the stainless steel hose, make sure that it is neither kinked nor damaged.

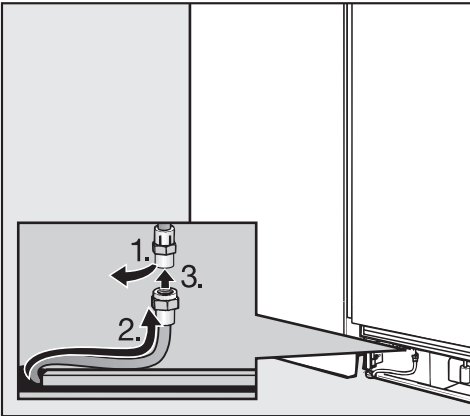

- Remove cap (1) from the water connection at the front of the appliance.
- Screw coupling nut (2) on stainless steel hose (3) onto the threaded union.
- Ensure that all connections are watertight.
- Turn on the stopcock slowly and check the whole water system for leaks.
- The appliance can then be connected to the electricity supply (see "Electrical connection").

After a maximum of 10 hours the first ice cubes will drop out of the ice cube maker and collect in the container.

Electrical connection U.K.

All electrical work should be carried out by a suitably qualified and competent person in strict accordance with current local and national safety regulations (BS 7671 in the UK).

The appliance is supplied with a mains cable and moulded plug ready for connection to an a.c. single phase 220-240 V 50 Hz supply.

Please ensure that the connection data quoted on the data plate match the household mains supply.

Connection should be made via a suitable switched socket which is easily accessible. It must not be located behind the appliance. For extra safety it is advisable to protect the appliance with a suitable residual current device (RCD).

Do not connect the appliance to the mains electricity supply by an extension lead. Extension leads do not guarantee the required safety of the appliance (e.g. danger of overheating).

This appliance must not be connected to the inverter of an autonomous power supply, e.g. a solar power system. When switching the appliance on, a surge in power could trigger the safety cut-out mechanism. This could damage the electronic unit.

The appliance must not be used with so-called energy saving devices. These reduce the energy supply to the appliance which could then become too warm. Using such devices could alter the specification of the product.

If the connection cable has to be replaced, this must be done by a suitably qualified and competent person.

Do not plug other appliances in behind this appliance

Non-rewireable plugs (BS 1363)

The fuse cover must be re-fitted when changing the fuse, and if the fuse cover is lost, the plug must not be used until a suitable replacement is obtained. The colour of the correct replacement cover is that of the coloured insert in the base of the plug, or the colour that is embossed in words in the base of the plug (as applicable to the design of the plug fitted).

Replacement fuses should be ASTA approved to BS 1362 and have the correct rating. Replacement fuses and fuse covers may be purchased from your local electrical supplier.

WARNING
THIS APPLIANCE MUST BE
EARTHED

Installation advice

Location

This appliance should not be installed where it is exposed to direct sunlight or directly adjacent to a heat-producing appliance such as an oven or a radiator. The higher the ambient temperature of the room, the longer the compressor has to run for. This increases the amount of energy the appliance requires to operate. The appliance should be installed in a dry, well-ventilated room.

If installation near a heat source is unavoidable, observe the following distances between the appliance and the heat source:

- 3 cm away from an electric oven or cooker
- 30 cm away from an oil- or coal-fired range.

When installing the appliance please be aware:

- The socket must be easily accessible in an emergency, not concealed behind the appliance.
- The plug and cable must not touch the rear of the appliance as they could be damaged by vibrations from the appliance.
- Do not plug in other appliances behind this appliance.

Important. In environments with high humidity condensation can build up on the exterior of the appliance. This can cause corrosion of the appliance walls. For prevention, it is advisable to install the appliance with sufficient ventilation in a dry and /or air-conditioned room. After installation make sure that the appliance door closes properly, the the correct ventilation gaps are provided and the appliance is installed in accordance with these installation instructions.

Climate range

The appliance is designed for use within certain climate ranges (ambient temperatures) and should not be used outside this range. The climate range of the appliance is stated on the data plate inside the appliance.

Climate range	Ambient room temperature
SN	+10 °C to +32 °C
N	+16 °C to +32 °C
ST	+16 °C to +38 °C
T	+16 °C to +43 °C

Operating in a room which is too cold will cause the compressor to switch off for too long, causing the internal temperature in the appliance to rise with the risk of food deteriorating and going off.

Safe operation of the appliance is only assured if it has been installed and connected in accordance with these operating and installation instructions.

Warning!

This appliance is very heavy and can tip forwards when the door is open. Keep the door shut until the appliance has been built in and secured within the building-in niche in accordance with these instructions.

Due to the size and weight of the appliance, installation must be carried out by two people.

The weight of the appliance when empty is:

KF 1801 Vi, KF 1811 Vi 206 kg
KF 1901 Vi, KF 1911 Vi 225 kg

Installation advice

Floor

To ensure the safe installation of the appliance and to guarantee its correct functioning, the floor to the niche where the appliance is to be installed must be smooth and even.

It must be made from strong, rigid material.

The appliance is extremely heavy when fully loaded, and for this reason it is imperative that the floor it stands on is able to bear its weight. If necessary, the advice of an architect or structural engineer should be sought.

When fully loaded, the approx. weight of the appliance is:

KF 1801 Vi, KF 1811 Vi 431 kg
KF 1901 Vi, KF 1911 Vi 537 kg

Door hinging

The appliance is supplied with fixed hinges. If you need to change the door hinging to the other side, please contact the Service Department.

On no account should you attempt to change the door hinging yourself. (N.B. Door hinge change not available in all countries).

Adjoining furniture/units

The appliance is screwed to the adjoining furniture/units to the side and above.

For this reason, it is essential that all furniture/units be fixed to the ground and/or wall.

Ventilation

The ventilation gaps must not be covered or blocked in any way. They should be dusted on a regular basis.

Side-by-side installation

This appliance may be installed "side-by-side" with another suitable refrigerator or freezer.

A side-by-side installation kit, available from Miele, is required. Ask your dealer which appliances are suitable for side-by-side installation with this appliance.

See the instructions supplied with the side-by-side installation kit for how to fix the appliances together.

Joining the two appliances together using the side-by-side installation kit

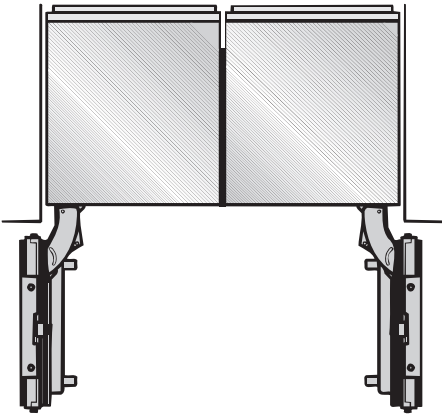

If the appliances are to be installed next to each other without a partition wall between them, they will need to be joined together using the side-by-side installation kit.

Installation with a partition wall using the side-by-side installation kit

The partition wall must be at least 16 mm thick.

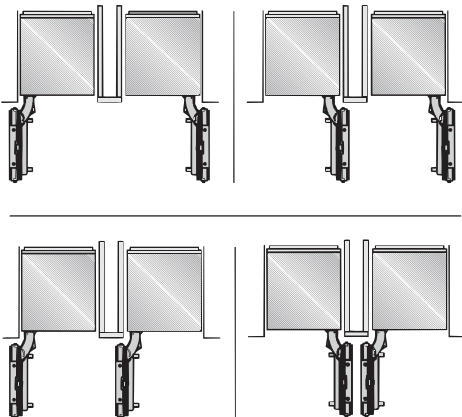

If the partition wall between the two appliances is **between 16 mm and 160 mm** thick, each appliance must be built into its own niche using the assembly parts supplied. The side-by-side installation kit is also required.

Installation with a partition wall without the side-by-side installation kit

If the partition wall between the two appliances is **more than 160 mm**, each appliance must each be built into its own niche using the assembly parts supplied (without using the side-by-side installation kit).

Installation advice

To limit the opening angle of the door

The door hinges are set ex-works to enable the door to be opened wide.

If the appliance door hits an adjacent wall when opened, for example, the opening angle can be limited to 90°.

- Open the appliance door.

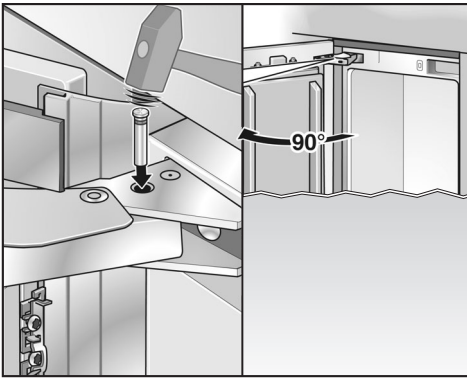

- Insert the pin into the hinge from above, as shown.

The door opening angle is now limited to 90°.

Appliance door dimensions (opening angle 90°)

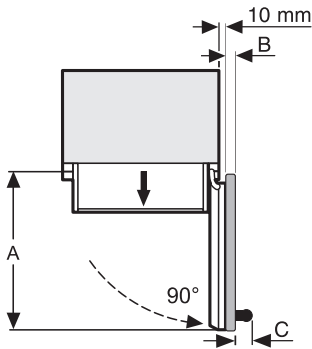

*The dimensions for the door fronts and handles will vary according to the individual kitchen.

	A	B	C
KF 1801 Vi, KF 1811 Vi	829 mm	Door front (max. 38 mm)*	Door handle*
KF 1901 Vi, KF 1911 Vi	982 mm	Door front (max. 38 mm)*	Door handle*

Appliance door dimensions (opening angle 115°)

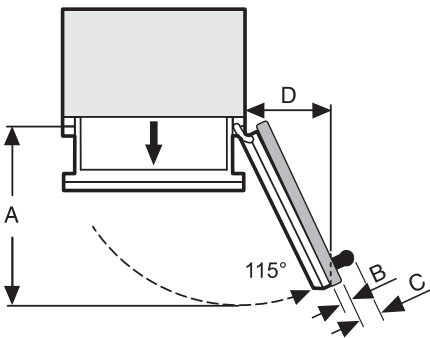

*The dimensions for the door fronts and handles will vary according to the individual kitchen.

	A	B	C	D
KF 1801 Vi, KF 1811 Vi	829 mm	Door front (max. 38 mm)*	Door handle*	363 mm
KF 1901 Vi, KF 1911 Vi	982 mm	Door front (max. 38 mm)*	Door handle*	428 mm

Building-in dimensions

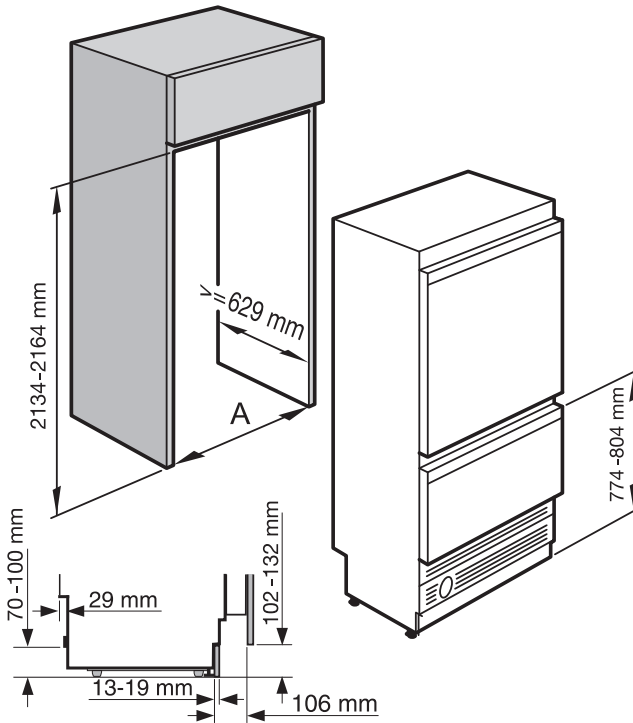

	Niche width A
KF 1801 Vi, KF 1811 Vi	762 – 765 mm
KF 1901 Vi, KF 1911 Vi	915 – 918 mm

Building-in dimensions

Laying the electrical cabling and the pipework for the mains water supply

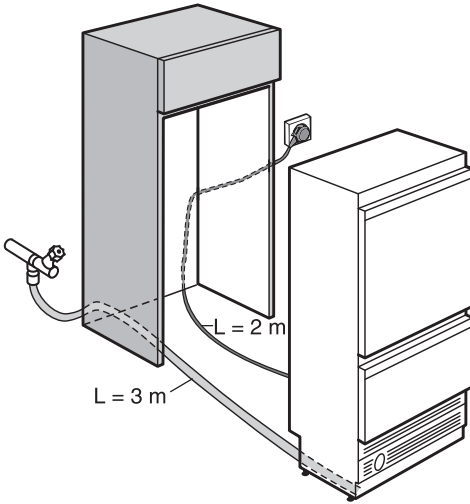

Door/drawer front dimensions

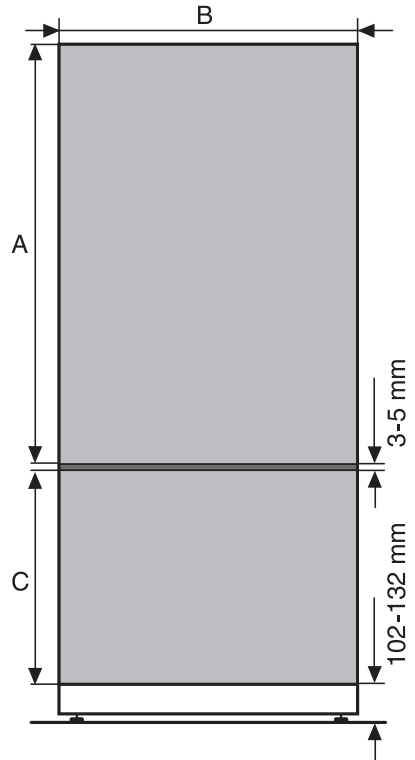

	A	B	C
KF 1801 Vi, KF 1811 Vi	1354 mm	756 mm	672 mm
KF 1901 Vi, KF 1911 Vi	1354 mm	908 mm	672 mm

Installation

Due to the size and weight of the appliance, it is essential that installation is carried out by two people.

Tools and accessories required

- Cordless screwdriver
- TX screwdriver (e.g. TORX)
- Hammer drill
- Drill bits in various sizes, depending on materials
- Hammer
- Socket wrench with: hexagonal bit (8 mm)
- Adhesive tape
- Pipe wrench
- Spirit level
- Try-square

To secure the building-in niche to a wall behind:

- suitable wall plugs/fixing screws depending on the type of wall.

Other

- Step ladder
- Sack barrow
- Wooden beams (min. 75 mm x 100 mm) if required, to prevent tipping; length depends on width of building-in niche
- Wood screws in various sizes

Optional accessories

- Side-by-side installation kit for side-by-side installation of two appliances

Stainless steel fronts

Stainless steel fronts and stainless steel look plinth grilles are available from your dealer or the Miele Spare Parts Department.

Weight of the door/drawer fronts

Before fitting the door/drawer fronts, ensure that the weight of the fronts do not exceed the maximum permitted:

Appliance	Max. weight of fridge door in kg	Max. weight of freezer drawer front in kg
KF 1801 Vi, KF 1811 Vi	47	10
KF 1901 Vi, KF 1911 Vi	38	14

Fitting a door front which is heavier than the maximum permitted could damage the hinges.

Building into a peninsular run

When built into a peninsular run, the rear of the building-in niche must be fitted with a kitchen furniture panel.

Building-in at the end of a run of units

If one side of the appliance is visible, a side panel is required.

The side panel must be fixed to the wall, the floor and any furniture/units above before the appliance is placed in the niche.

The size of the side panel must match that of the furniture panel opposite.

Installation

Aligning the building-in niche

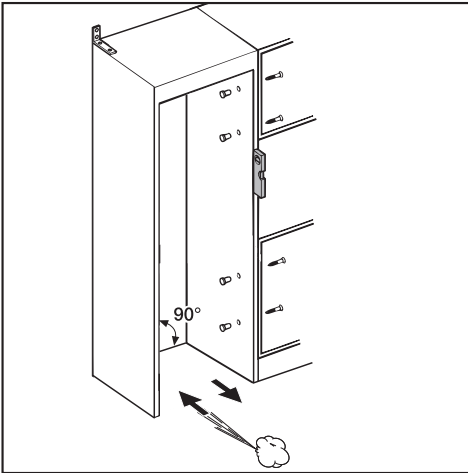

The building-in niche must be carefully aligned using a spirit level before installing the appliance. The corners must be at right angles, as otherwise the furniture door will not align correctly with the 4 corners of the building-in niche.

- The side panels of the building-in niche must be even.
- The niche panels must be at least 16 mm thick.
- The plinth facing must be at least 13 mm thick (or preferably 19 mm).

Checking the building-in niche

- The building-in dimensions now need to be checked.
- Check the position of the electrical and plumbing connections (see "Electrical connection" and "Mains water connection").
- Check that all surrounding furniture/units are securely fixed to the wall.
- Check the surrounding furniture/units for possible clashes when opening doors.

Before installation

Warning!

This appliance is very heavy and can tip forwards when the door or freezer drawer is open.

- Before installation, take any accessories out of the appliance and/or from the back of the appliance.
- Remove any cable clips from the back of the appliance.
- Check that all parts at the back of the appliance are unhindered. Carefully remove any hindrance.

To protect the floor from damage when installing the appliance,

- secure an off-cut of flooring (e.g. lino) to the floor in front of the installation area.

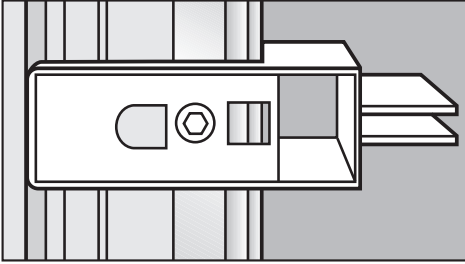

The appliance can be rolled along the floor using the wheels at the back.

Preparing the niche

 Keep the door and drawer to the appliance closed until it is fixed inside the building-in niche.

Due to the size and weight of the appliance, please ensure that once secured in the niche, it can no longer tip forwards.

Installation accessories

All the fixings required for installation are supplied with the appliance. The plastic bags are marked with letters for easy identification.

Each fitting stage is indicated by the letter on the bag needed for that stage.

- Do **not** remove the installation aids from the appliance door/drawer. These will be required later when the appliance is installed in the building-in niche.
- Check the appliance for damage during transportation.

Do not install a damaged appliance!

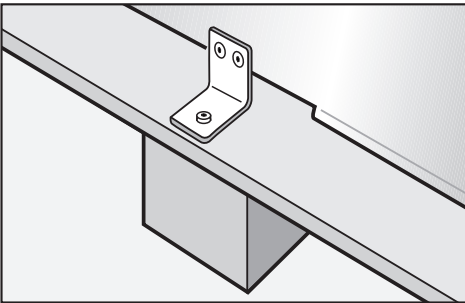

- Unscrew the bracket that is holding the appliance to the delivery pallet.

 **Warning!**
Please bear in mind that the appliance is no longer secured to the pallet!

- With the help of several people as required, carefully lift the appliance from the pallet, starting with the back of the appliance.

Installation

Anti-tipping mechanism

The anti-tipping mechanism supplied ① is used to secure the building-in niche ② to the wall, preventing the appliance from tipping forwards.

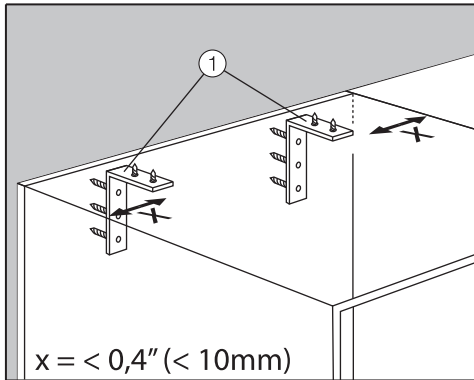

⚠ Danger of tipping.
The building-in niche must be securely fixed to the wall behind using a number of screws to avoid the appliance tipping when it is fixed into the niche later.

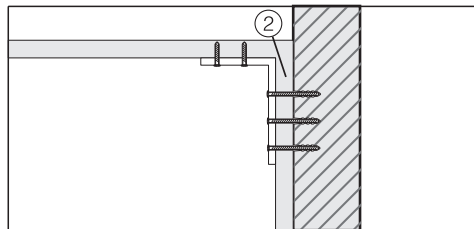

Use two anti-tipping mechanisms for each appliance or four for each side-by-side pair of appliances.



- Place the anti-tipping mechanisms ① on the left- and right-hand sides of the building-in niche, leaving $<math><math><math>$$</math></math></math></math> distance to the side walls.$
- Mark the drilling position onto the niche back walls and top panel through the holes in the anti-tipping mechanisms.
- Put the anti-tipping mechanisms in a safe place - they will be required later.

Fixing screws for different uses and types of material are supplied in the accompanying pack. If these are not suitable for the anti-tipping mechanism in your installation, you will need to secure it by alternative means.



- Secure the building-in niche to the wall.

For a building-in niche **with** a back panel

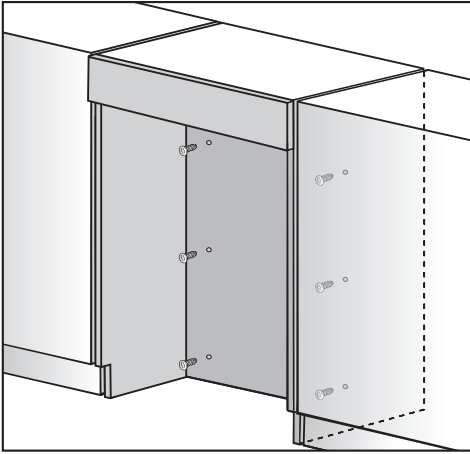

- screw the back panel directly onto the wall behind in a number of places. Use suitable wall plugs/fixing screws depending on the type of wall.

For a building-in niche **without** a back panel

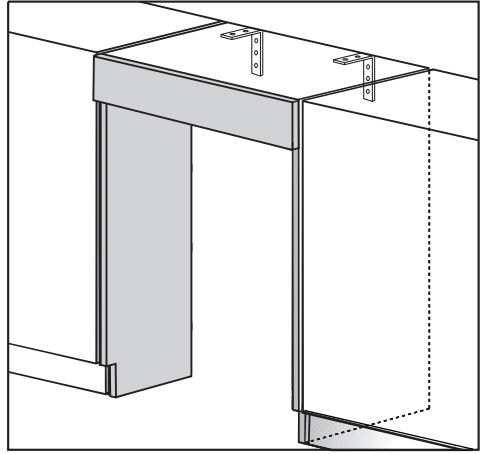

- screw the building-in niche to the wall behind using a number of suitable angled fixing brackets. Use suitable wall plugs/fixing screws depending on the the type of wall.

Installation

An alternative anti-tipping mechanism

The appliance can alternatively be secured with a wooden beam across the top of the appliance. If this method is used, then there must not be any gap between the appliance and the wooden beam.

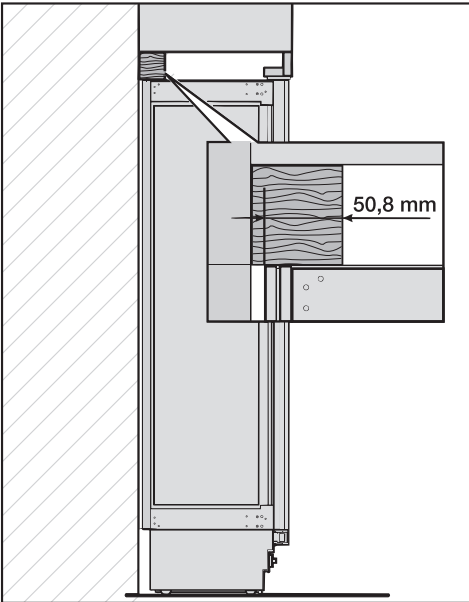

- The wooden beam must be at least 75 mm x 100 mm thick.
- The length must be the same as the width of the building-in niche.
- If the building-in niche is deeper than the appliance, a thicker wooden beam should be used.
- The wood must cover the appliance to a depth of at least 50.8 mm (see diagram).

- Mark the position of the lower edge of the wooden beam on the rear wall of the building-in niche.
- Select screws of a length depending on the thickness of the wood.

Use the number of screws appropriate to the niche width to ensure that the wooden beam is securely fixed.

- Check where the upright wall supports are in the back of the niche, and mark the drill holes in the wooden beam accordingly.
- Drill the holes in the wooden beam.
- Secure the wooden beam to the back wall of the niche.

Now prepare the mains water connection for the appliance (see "Mains water connection").

Placing the appliance in the niche

If you are installing two appliances side by side, now secure the appliances to one another (see the instructions for the side-by-side installation kit).

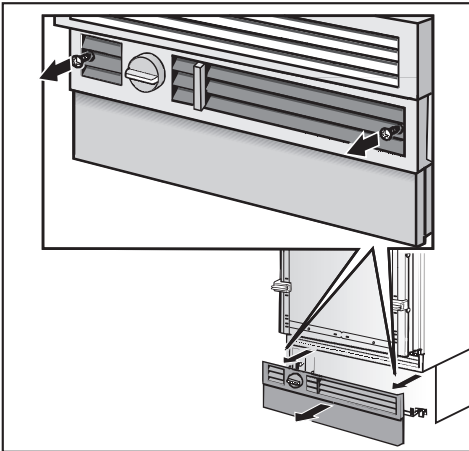

Connection should be made via a suitable switched socket. The socket should be close to the appliance and easily accessible. Otherwise the appliance should be connected via an external all-pole switch with a sufficient contact gap in the open position.

When installing two appliances side by side, each appliance must have its own separate socket.

- Secure the cable to prevent it becoming caught:
Tie a piece of string to the middle of the cable, and as the appliance is being pushed into the niche, pull the cable forward underneath the appliance ②.
- Push the appliance into the niche.

- Unscrew the plinth facing.

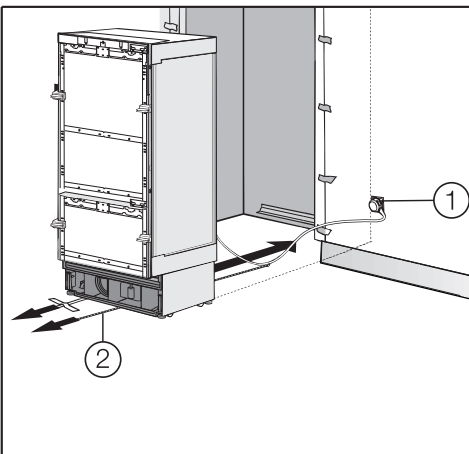

- Push the appliance into the niche.
If the appliance does not slide easily into the niche (e.g. if the floor is uneven),
 - adjust the rear feet slightly (see "Aligning the appliance").

Then push the appliance into the niche, taking care not to damage the electrical and mains water connections.

- Remove the edge protector from the adjacent furniture fronts.

- Protect the adjacent furniture fronts.
- Plug in the appliance ①.

Installation

Aligning the appliance

- Align the appliance with neighbouring furniture fronts.

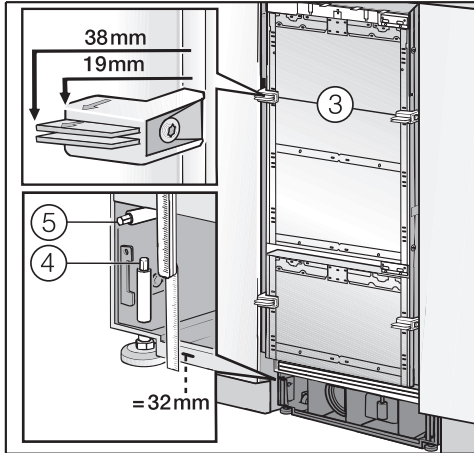

The installation aids ③ on the appliance door are suitable for 19 mm or 38 mm furniture door fronts.

The adjustable feet at the front and back of the appliance can be adjusted from the front.

- Front feet:
Adjust from the top with a socket wrench with hexagonal bit (8 mm) ④.
- Rear feet:
Adjust with a (cordless) screwdriver or a socket wrench with hexagonal bit (8 mm) ⑤.
- Place a spirit level on the installation aids ③ on the appliance door to check the appliance's alignment.

Important:
work methodically when adjusting the feet: always alternately left, right, etc.

- A mark is located on the appliance base. When adjusting the height, this mark needs to be aligned at 32 mm from the floor. Unscrew the feet until the mark on the base has reached 32 mm. The 32 mm mark is for aligning the appliance in a niche height of 2134 mm.

Important:
Adjust the feet **only until** the marking on the base has reached the 62 mm point (max. niche height 2164 mm). Otherwise the rear foot adjustment mechanism will get damaged.

- Check the alignment of the appliance again using the spirit level.

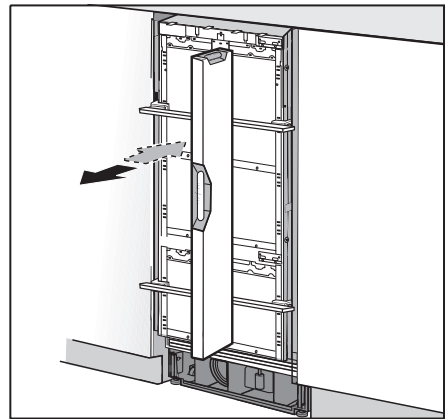

- If a wooden beam has been fitted above the appliance to prevent tipping, the appliance height needs to be adjusted to fit snugly under the wooden beam.

Securing the appliance in the niche

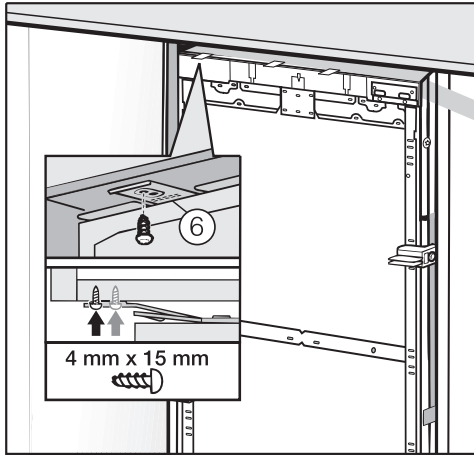

- Screw the lugs for the fixing plates (6) into the furniture/units above the appliance.

If it is not possible to secure the appliance above, it can be attached to the niche at the sides only.

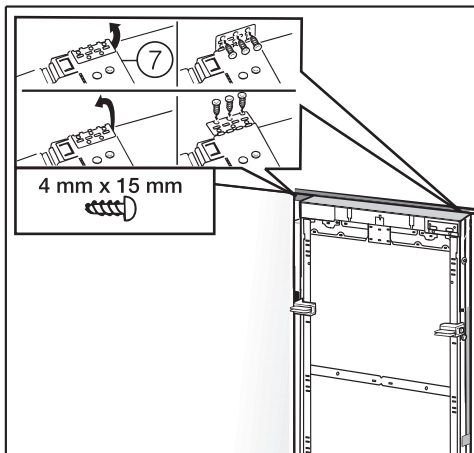

- Pull out the lugs for the side fixing plates (7).

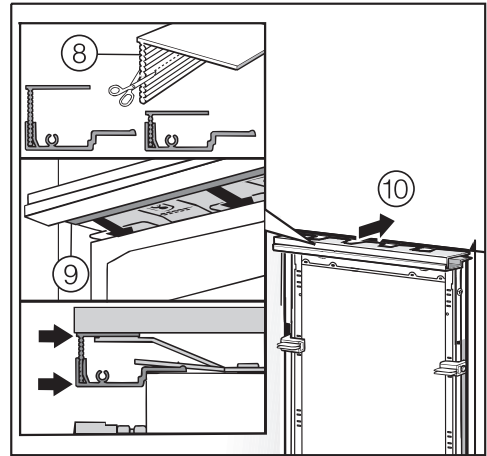

- Screw on the lugs for the side plates.
- If necessary, cut trim (8) to the necessary depth.
- Join the two pieces of trim together (9).
- Click them into position (10).

Installation

When installing two appliances **side by side**, the filler strips for the two appliances need to be joined together to form one long strip.

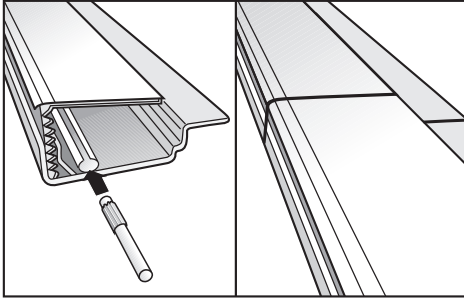

- Insert the joining peg from the side-by-side kit halfway into the channel in the filler strip for the left-hand appliance.
- Then insert the free half of the joining peg into the channel on the other strip, and press the two strips together.
- Click the two filler strips into place above the appliances.

- Open the appliance door and drawer.

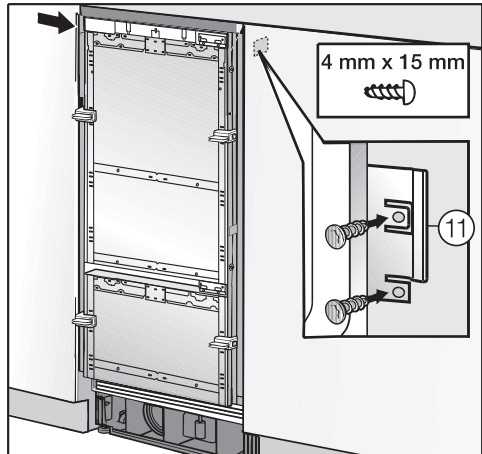
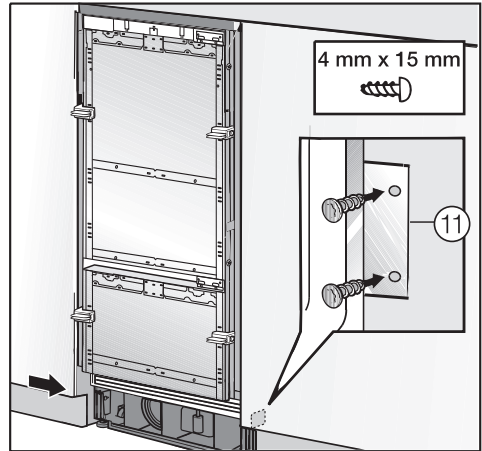

- Screw the lugs for the fixing plates ⑪ into the furniture/units adjacent to the appliance.

In a side-by-side combination, only the external panels of the two appliances can be secured to the furniture wall.

Connect the appliance to the water inlet hose (see "Mains water connection").

Preparing the furniture front

To ensure the correct alignment of the furniture fronts, it is vital to fix the upper furniture door before fixing the lower one.

- Load the door shelves in the refrigerator door.
- Open the appliance door as far as it will go.

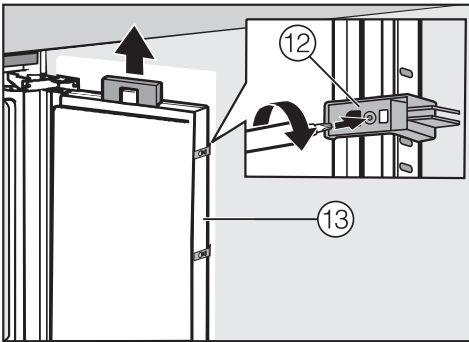

- Unscrew the installation aids ⑫ and angle trim ⑬ from the door.
- Put the angle trim ⑬ and screws in a safe place - they will be required later.
- Take the cover off the light contact switch.
- Close the appliance door.

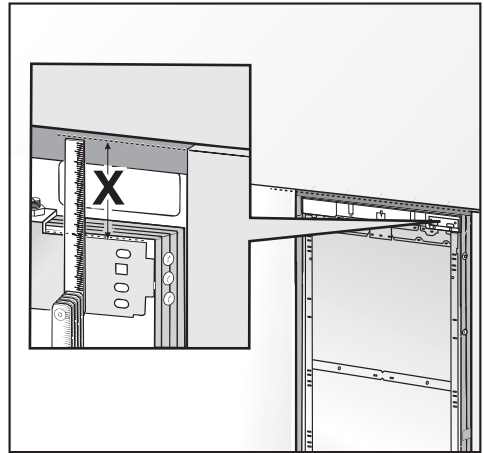

- Measure gap **X** between the adjusting bar and the upper edge of the adjacent furniture front.
- Remove the two nuts from the appliance door, and place them in a safe place - they will be required later.
- Place the furniture front on a firm surface, with the external side facing downwards (place on a blanket or similar to avoid it becoming scratched).

Installation

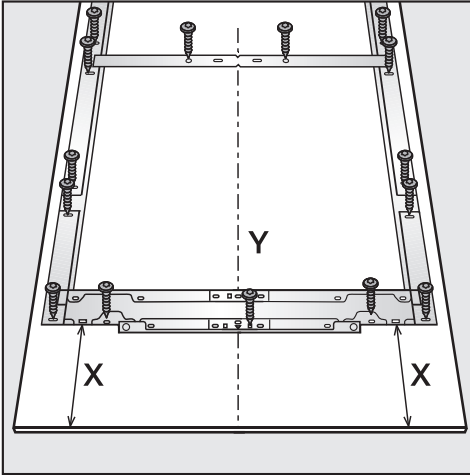

- The fixing frame has several different types of holes to take account of a variety of furniture fronts.
- When securing the frame, always screw into the strongest part of the furniture door.
- To do this, select screws which are slightly shorter than the thickness of the furniture door.
- Screw the appliance handle to the furniture door from the inside.

- Mark gap **X** on the inside of the furniture front.
- Similarly, locate and mark the midpoint **Y** on the furniture front.
- Remove the fixing frame from the appliance door and position it corresponding to the markings on the furniture front.
- Pre-drill the holes.
- Screw the fixing frame to the furniture front, using at least one screw for each fixing point.



- Secure the fixing frame to the top of the furniture front, using at least 10 screws:

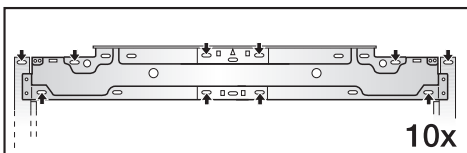

Securing and aligning the furniture door

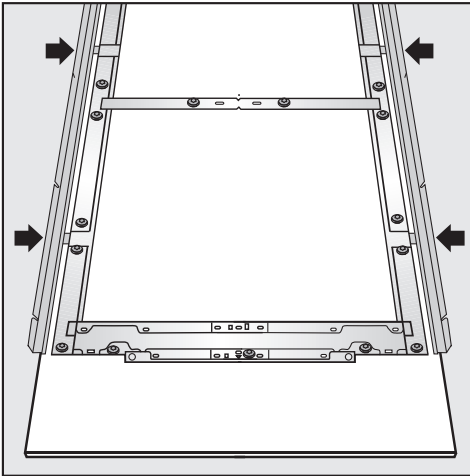

- Insert the angle trim as far as it will go into the spaces in the frame, as shown.

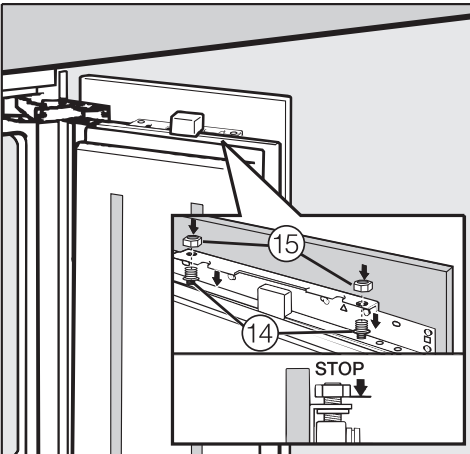

- Open the appliance door and hang the furniture front on its frame onto the threaded bolts, as shown 14



- Press the angle trim on both sides into the white plastic frame, and screw them down securely. Replacement screws for this can be found in the plastic bag marked with the letter E.
- Screw the nuts 15 loosely onto the threaded bolts - but do not tighten yet.
- Close the appliance door and check the distance between the door and neighbouring furniture doors.

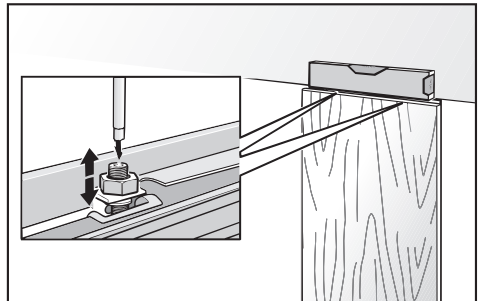

- Align the door to the side by sliding it over the threaded bolts 14.
- Align the depth of the door via the gaps in the angle trims. Then screw the angle trims into position.
- Now tighten the top nuts 15. The door is now fixed.

Installation

Repeat the steps from "Preparing the furniture fronts" to fit the furniture front to the freezer drawer.

The positioning of the freezer drawer front must be aligned to that of the refrigerator door front.

When fitting the drawer front, bear in mind the gap between the drawer and door fronts:

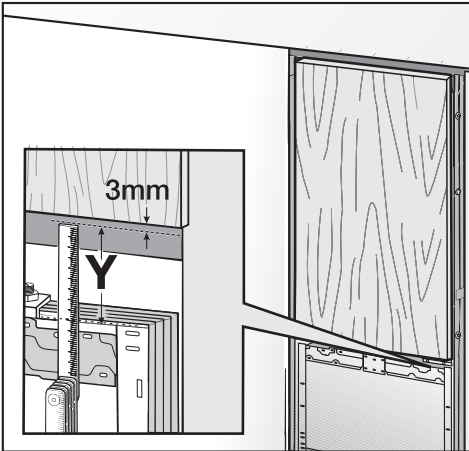

- Measure gap **Y** between the adjusting bar on the freezer drawer and the refrigerator door.
- A gap of 3 mm needs to be maintained between the drawer and refrigerator door.

Fitting the fixing brackets

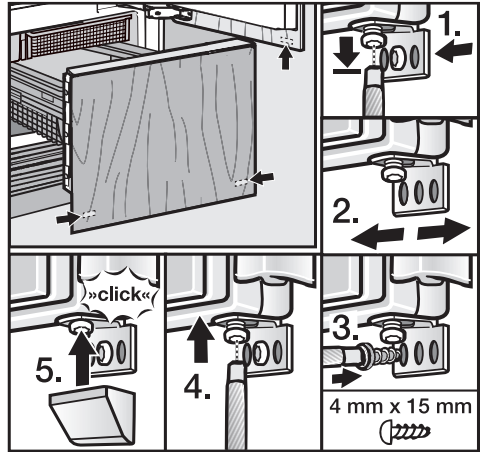

The fixing brackets are used to secure the furniture fronts at the bottom.

- Open the freezer drawer as far as it will go.
- Loosen the screws (1).
- Position the fixing bracket on the appliance door (2) and pre-drill a hole in the furniture front.



- Screw the fixing bracket securely to the furniture front (3).
- Now tighten the screw (4).
- Fit the cover to the fixing bracket (5).

The number of fixing brackets required will depend on the material and width of the furniture front.

Securing the covers

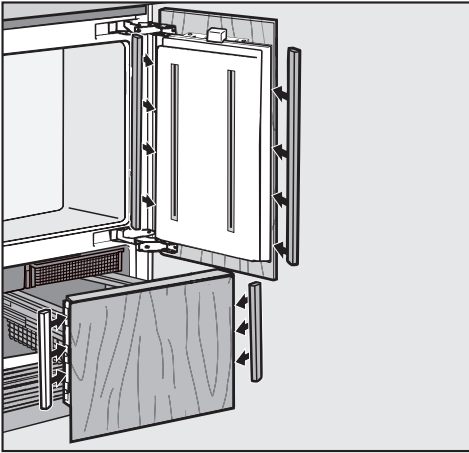

- Fit the plastic cover strips to the refrigerator door and freezer drawer, clicking them into the space between the appliance door/drawer and the furniture front, starting at the bottom and working up to the top.

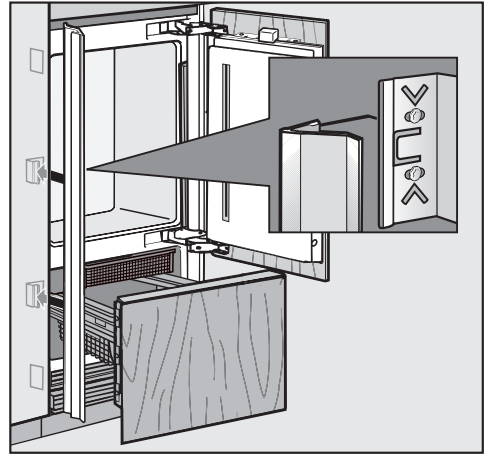

- Now attach the covers onto the retaining clips on both sides. In the case of side-by-side installation, the cover strips are only required on the outer side.

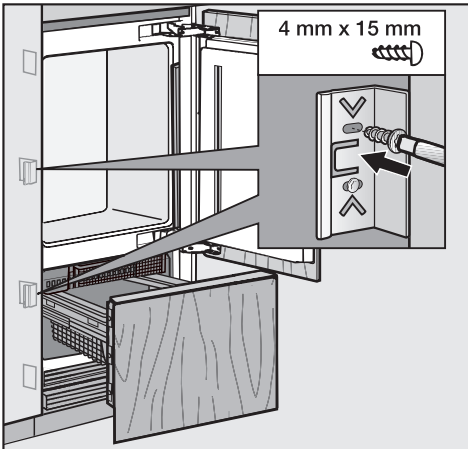

- Secure the retaining clips for the space covers on both sides.

Installation

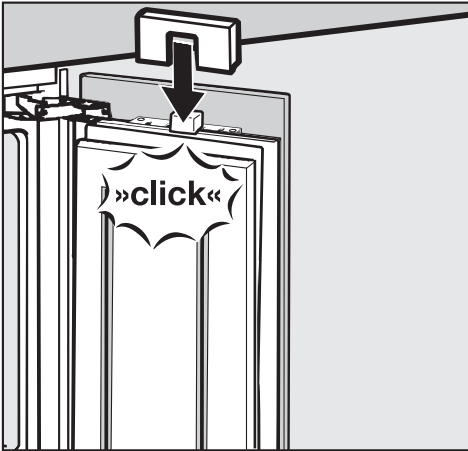

- Fit the cover to the light contact switch so that it clicks into place as shown.

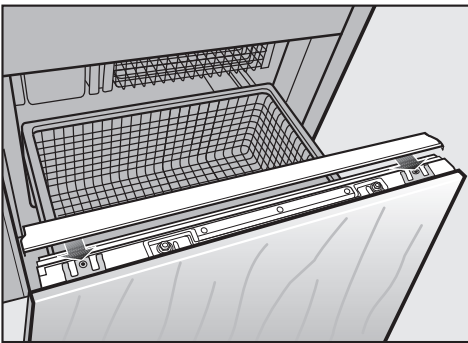

- Fit the cover to the top edge of the freezer drawer, as shown.

Fitting the plinth facing

Do not cover the vents in the plinth. This could result in damage to the appliance.

- Trim the plinth facing to the required length and height (cut along the lower edge of the plinth facing where it touches the floor).

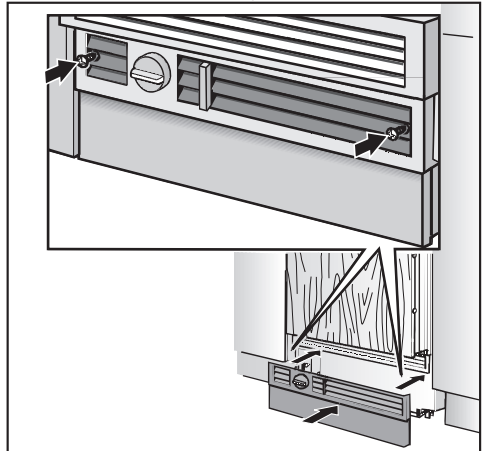

- Secure the plinth to the appliance, and attach the cover caps supplied.

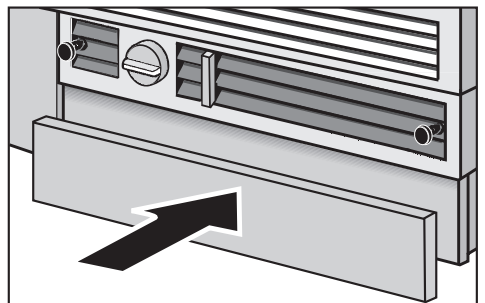

- Now fit the plinth facing.

Fitting the air separator

The air separator in the bottom of the ventilation grille separates air entering the appliance from that leaving it. It also stops warm air flowing into the appliance, which would cause a short circuit.

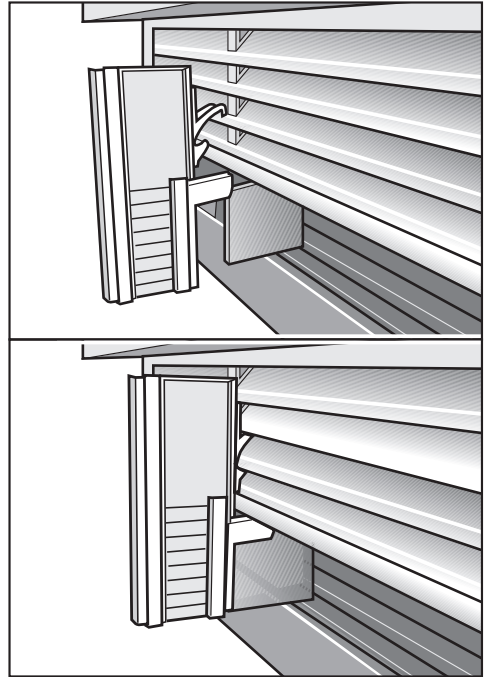
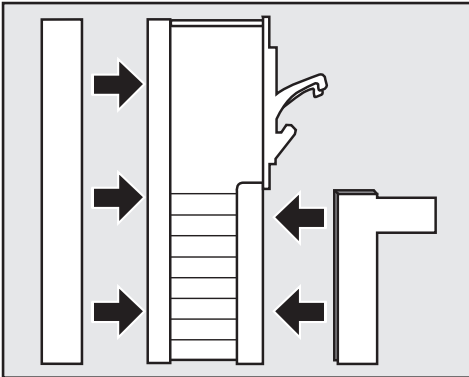

- If necessary the three parts of the air separator can be shortened to the correct height.
- Replace the foam parts in the sides.

- Clip the air separator to the left and right of the partition in the exhaust grille. Make sure that it clicks into place and that the foam partition is guided under the exhaust grille.

United Kingdom

Miele Co. Ltd.
Fairacres, Marcham Road
Abingdon, Oxon, OX14 1TW
Customer Contact Centre Tel: 0330 160 6600
E-mail: mielecare@miele.co.uk
Internet: www.miele.co.uk

Australia

Miele Australia Pty. Ltd.
ACN 005 635 398
ABN 96 005 635 398
1 Gilbert Park Drive, Knoxfield, VIC 3180
Tel: 1300 464 353
Internet: www.miele.com.au

China

Miele (Shanghai) Trading Ltd.
1-3 Floor, No. 82 Shi Men Yi Road
Jing' an District
200040 Shanghai, PRC
Tel: +86 21 6157 3500, Fax: +86 21 6157 3511
E-mail: info@miele.cn, Internet: www.miele.cn

Miele (Hong Kong) Limited

41/F - 4101, Manhattan Place
23 Wang Tai Road
Kowloon Bay, Hong Kong
Tel: (852) 2610 1331, Fax: (852)2610 1013
Email: mielehk@miele.com.hk

India

Miele India Pvt. Ltd.
Ground Floor, Copia Corporate Suites
Plot No. 9, Jasola
New Delhi - 110025
Tel: 011-46 900 000, Fax: 011-46 900 001
E-mail: customercare@miele.in, Internet: www.miele.in

Ireland

Miele Ireland Ltd.
2024 Bianconi Avenue
Citywest Business Campus, Dublin 24
Tel: (01) 461 07 10, Fax: (01) 461 07 97
E-Mail: info@miele.ie, Internet: www.miele.ie

Manufacturer: Miele & Cie. KG

Carl-Miele-Straße 29, 33332 Gütersloh, Germany

Miele

Malaysia

Miele Sdn Bhd
Suite 12-2, Level 12
Menara Sapura Kencana Petroleum
Solaris Dutamas No. 1, Jalan Dutamas 1
50480 Kuala Lumpur, Malaysia
Phone: +603-6209-0288
Fax: +603-6205-3768

New Zealand

Miele New Zealand Limited
IRD 98 463 631
Level 2, 10 College Hill
Freemans Bay, Auckland 1011, NZ
Tel: 0800 464 353
Internet: www.miele.co.nz

Singapore

Miele Pte. Ltd.
163 Penang Road
04 - 03 Winsland House II
Singapore 238463
Tel: +65 6735 1191, Fax: +65 6735 1161
E-Mail: info@miele.com.sg
Internet: www.miele.sg

South Africa

Miele (Pty) Ltd
63 Peter Place, Bryanston 2194
P.O. Box 69434, Bryanston 2021
Tel: (011) 875 9000, Fax: (011) 875 9035
E-mail: info@miele.co.za
Internet: www.miele.co.za

United Arab Emirates

Miele Appliances Ltd.
P.O. Box 11 47 82
Gold & Diamond Park, Sheikh Zayed Road
Building 6 / Offices Nos. 6-214 to 6-220
Dubai
Tel: +971-4-341 84 44
Fax: +971-4-341 88 52
E-Mail: info@miele.ae
Internet: www.miele.ae

KF 1801 Vi, KF 1811 Vi
KF 1901 Vi, KF 1911 Vi