

FR GUIDE D'UTILISATION
EN GUIDE TO INSTALLATION
ES MANUAL DE UTILIZACIÓN
PT GUIA DE UTILIZAÇÃO
DE BETRIEBSANLEITUNG

Hotte décorative

Decorative Hood

Campana extractora decorativa

Exaustor decorativo

Dekor-Dunstabzugshaube

De Dietrich 



FR 02

EN 18

ES 34

PT 52

DE 68

Dear Customer,

When you discover De Dietrich products you experience the same feelings that only objects of value can arouse.

You are immediately attracted as soon as you see them. The quality of the design is illustrated by its timelessness, degree of refinement and elegance, and high standard of finish, resulting in perfect harmony between different appliances.

Then comes the irresistible urge to touch. De Dietrich design makes the most of sturdy and high-quality materials; priority is given to authenticity.

By combining the most advanced technologies with the best materials, De Dietrich makes products of the highest quality for the benefit of all those who love cooking.

We hope you are extremely satisfied with this new appliance and will be happy to receive your suggestions and to answer your questions. Please contact our customer service department or use our Internet site.

We invite you to register your product at www.de-dietrich.com to take advantage of all the benefits the brand has to offer.

Thanking you for your confidence.

De Dietrich

*Find further details on the brand at www.de-dietrich.com
Visit La Galerie De Dietrich, 6 rue de la Pépinière in Paris VIII
Open Tuesday to Saturday 10 a.m. to 7 p.m.*

De Dietrich Customer Service 0892 02 88 04

1 / USER NOTICES	
• Safety guidelines _____	04
• Care for the environment _____	05
• Description of your appliance _____	06
2 / INSTALLING YOUR APPLIANCE	
• Using the recycling mode _____	07
• Electrical connection _____	08
• Assembling the hood _____	09
3 / USING YOUR APPLIANCE	
• Control panel description _____	10
4 / CARING FOR AND CLEANING YOUR APPLIANCE	
• Cleaning the filter and the fat drip tray _____	13
• Changing the carbon filter _____	13
• Cleaning the outer surfaces _____	13
• Changing a bulb _____	13
5 / TROUBLESHOOTING _____	14
6 / AFTER-SALES SERVICE _____	15

**Important**

Keep this user guide with your appliance. If the appliance is ever sold or transferred to another person, ensure that the new owner receives this user guide. Please become familiar with these recommendations before installing and using your oven. They were written for your safety and the safety of others.

• SAFETY GUIDELINES

- This appliance was designed for use by private individuals in their homes.
- This appliance is not intended for use by persons (including children) with impaired physical, sensory or mental capacities, or by inexperienced or untrained persons, unless they have received prior instruction or supervision in its operation by a person responsible for their safety. Children must be supervised to prevent them from playing with the appliance.
- When you receive the appliance, unpack it or have it unpacked immediately. Check its overall condition. Make note of any concerns or reservations on the delivery slip and make sure that you keep a copy of this form.
- Your appliance is intended for standard household use. Do not use it for commercial or industrial purposes or for any other purpose than that for which it was designed.
- Do not modify or attempt to modify any of the characteristics of this appliance. That would be dangerous to your safety.
- Repairs must only be performed by an approved specialist.
- Always unplug the hood before cleaning it or performing other maintenance work.
- Provide adequate ventilation for the room in the case of simultaneous use of the hood and other appliances powered by an energy source other than electricity. This will prevent the hood from aspirating the combustion gases.
- You should never “flambé” dishes under the hood or operate gas rings under the hood without placing cookware on them (the flames sucked up into the hood can damage the appliance).

**Note**

In the case of a kitchen heated by a device connected to a chimney (a stove, for example) the “recycling” version of the hood should be installed. Do not use the hood without the cartridge filters. Suitable ventilation should be provided in the room when the hood is used at the same time as appliances operated by gas or another combustible fuel.

- When frying food under the appliance, you must carefully monitor the preparation at all times. Oils and grease brought to very high temperatures can catch fire.
- Respect the recommended cleaning and filter replacement frequency. The accumulation of grease deposits may cause a fire.
- The hood should never be used over a combustible fuel burning stove (wood, coal, etc.).
- Never use steam or high-pressure devices to clean your appliance (requirement imposed by electrical safety concerns).
- As part of our commitment to constantly improving our products, we reserve the right to make changes to them based on technological advances to their technical, functional and/or aesthetic properties.
- In order to easily locate the reference information for your appliance, we recommend that you note them on the “After-Sales Service Department and Customer Relations” page. (This page also explains to you where to find this information on your appliance.)

• CARE FOR THE ENVIRONMENT

–This appliance's packing materials are recyclable. Please recycle the packaging and help protect the environment by placing it in the recycling bins provided by your local council.



– Your appliance also contains various recyclable materials. It therefore carries this logo to indicate that used appliances should not be disposed of together with other waste. The manufacturer will arrange for the appliance to be recycled properly, in accordance with European directive 2002/96/EC on Waste Electrical and Electronic Equipment. Consult your local authority or your retailer to find the drop-off points for used appliances nearest to your home.

– We thank you for your help in protecting the environment.



Note

Installation should only be undertaken by qualified fitters and technicians.



Note

Before using the carbon filter for the first time, remove the protective film.



Note

The accessible parts of this appliance can become hot when used with cooking appliances.

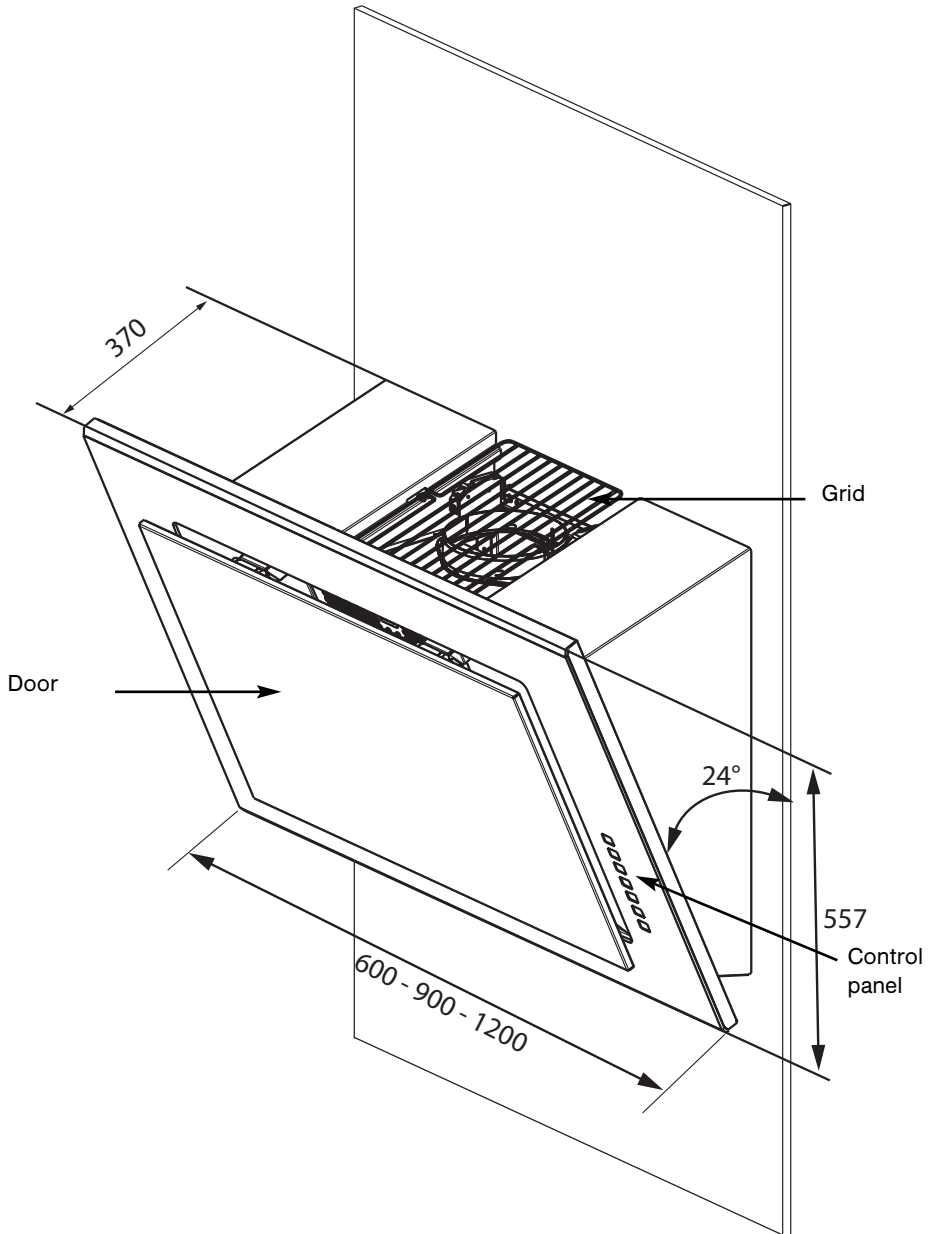
• DESCRIPTION OF YOUR APPLIANCE

- The appliance must be unplugged during installation or when any repair or maintenance work is being carried out.
- Ensure that the network voltage corresponds to the voltage noted on the identification plate located inside the hood.
- If the electrical installation at your residence requires any changes in order to hook up your appliance, call upon a professional electrician.
- This cooker hood is used in recycling mode with an activated carbon filter which traps cooking smells (section 4: changing the carbon filter). It can be used in evacuation mode with the addition of optional ducts.

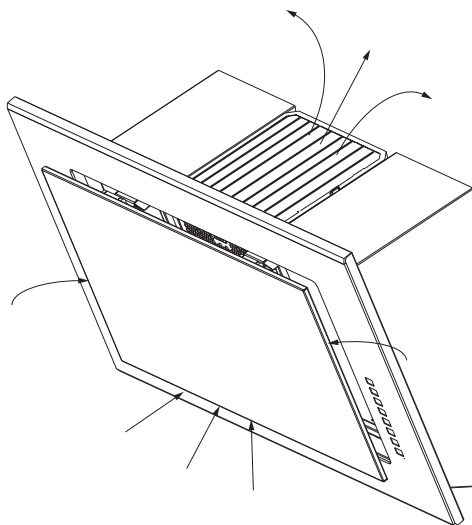

• **ELECTRICAL CONNECTION**

During installation and maintenance operations, the appliance must be unplugged from the electrical grid; fuses must be cut off or removed.

Electrical connections must be carried out after assembly and fixing.

Ensure that:

- the electrical installation has sufficient voltage,
- the electrical wires are in good condition
- the diameter of the wires complies with the installation requirements.

Note

This appliance is delivered with a H 05 VVF power cord that has three 0.75-mm² conductors (neutral, phase and ground). It must be connected to the 220-240V single phase mains supply via an IEC 60083 standard socket which must remain accessible after installation or by incorporating a switch in the fixed wiring, as required by installation regulations.

We cannot be held responsible for any accident resulting from an non-existent, defective or incorrect ground lead. The fuse in your set-up must be 10 or 16 amperes. If the power cable is damaged, call the after-sales service department in order to avoid danger.

Note

If the electrical installation in your residence requires any changes in order to hook up your appliance, call upon a professional electrician.

Note

If the hood displays any malfunctions, unplug the appliance or remove the fuse corresponding to the electrical socket where your appliance is plugged in.

• ASSEMBLING THE HOOD



Note

The hood must be installed in compliance with all applicable regulations concerning the ventilation of premises. In France these regulations are described in DTU 61.1 from the CSTB. In particular, the evacuated air should never be carried to a duct used to evacuate smoke from appliances that use gas or other combustible fuels. Disused ducts may only be used after approval from a competent specialist.

The distance between the hob and the lowest part of the cooker hood must be between 50 and 65 cm (use the template supplied with your appliance).

- Draw a horizontal line at the chosen height.
- Position the drilling template against the wall, use wall plugs and screws suitable for your type of wall.
- Drill the holes. Insert the wall plugs.
- Screw the attachment strip to the wall.
- Fully unscrew screws 2 to withdraw the hook as far as it will go.
- Locate the appliance on the strip.
- Tighten screws 2 up again until the appliance is clamped flat against the wall.
- Screw 1 is used to adjust the horizontal positioning of the cooker hood.
- Open the door of the hood, remove the cartridge filter, and put the anti-lift screws (3) in place.
- Place the carbon filter in the filter cartridge with the 2 metal attachment brackets (see section on changing the carbon filter).
- Secure the grid (4) in place with the 2 screws provided.

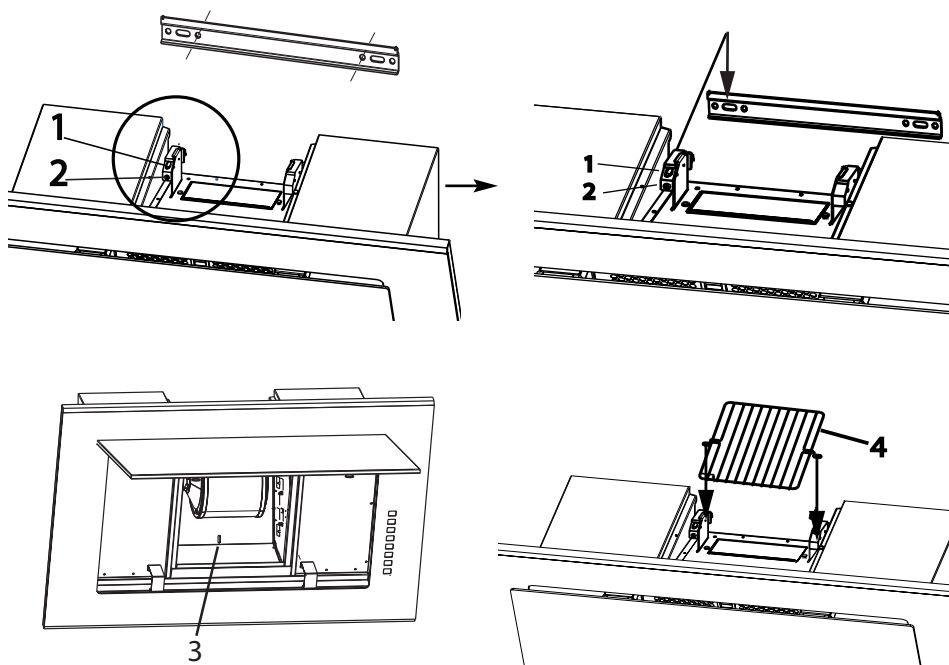



Eolysis



Light



Timer



Boost



Speed 3



Speed 2



On/Off - Speed 1



Tip

This Guide to Installation and Use is valid for several models. There may be minor differences between the details and fittings on your appliance and the description provided.

CONTROL PANEL DESCRIPTION

① • On/Off

Pressing the ① button starts the hood in speed 1 (the ① button is illuminated).

A long press on the ① button turns the hood off.

• Cartridge filter saturated

The ① button flashes (1 short flash) for 2 minutes after the hood stops to signal that the cartridge filters must be cleaned (see section “Cleaning the cartridge filter”).

Give a long press (more than 2 sec) on ① to unlock the “saturation” function.

• Carbon filter saturated

The ① button flashes (2 short flashes) for 2 minutes after the hood stops to signal that the carbon filters must be cleaned (see section “Changing the carbon filter”).

Give a long press (more than 2 sec) on ① to unlock the “saturation” function.

2^{II} • Change speed

Once the hood has started, you can modify the suction speed by pressing 2^{II} for speed 2 (2^{II} is lit) or 3^{III} for speed 3 (3^{III} is lit).

^{III}
The BOOST function allows your hood to remain at maximum speed 4 for 10 minutes, before switching back to speed 2.

• Configure recycling mode (or evacuation mode as an optional extra)

A long press (more than 2 sec) on the 2^{II} and 3^{III} buttons allows you to select Evacuation or Recycle mode. The 2^{II} and 3^{III} buttons are lit and the ① or ^{III}BOOST button flashes.

A short press on ① selects recycle mode (the ① button flashes and the ^{III}BOOST button is off).

A short press on ^{III}BOOST selects evacuation mode (the ^{III}BOOST button flashes and the ① button is off).

A short press on ⑩ confirms the configuration (or automatic set after 10 sec). The hood's default mode is evacuation.



- **Delayed stop**

At the end of cooking, you can select the  button to stop the hood. This function will ensure that suction continues for a further 10 minutes at the selected speed.

 flashes and the power indicator is illuminated.

To cancel the delayed stop, press the same button and the delay function will be deactivated.







- **Light**

Press the  button briefly to switch the hood's light on or off.





- **Eolysis function**



Pressing briefly on the  button starts the function. For an hour, the hood alternates between a 5-minute interval running in speed 1 and a 10-minute pause.. The  button is lit and the  indicator flashes.



At the end of this time, the hood stops on its own. To stop the function, press  once more.

Programming the Eolysis function

A long press on the  button activates programming.

The  button flashes alternately with the  button, indicating the start of programming.

Each short press on the  button increases the eolysis time by one hour (from 1 hour to a maximum of 9 hours) and after 9, this display goes back to 1. The  button flashes alternately with the  button (the number of successive flashes is the number of hours selected).

Programming is confirmed automatically after 25 seconds or by a short press on  . (The  button flashes alternately with the  button).

Programming is confirmed by pressing the  button; press it a second time to cancel.

- **Auto stop fan**

If you forget to turn off the hood, it will automatically turn itself off after nine hours of operation.

- **Auto stop lighting**

If you forget to turn off the light on your hood, it will turn itself off automatically after 9 hours.

**Note**

Disconnect the appliance by unplugging it or using the circuit breaker before cleaning it or performing other forms of maintenance. Regular maintenance of your appliance is a guarantee of proper functioning, good performance and durability.

Failure to respect the guidelines for cleaning the appliance and filters may cause fires. Please ensure that you adhere carefully to the maintenance recommendations.

• **CLEANING THE FILTER (1) AND THE FAT DRIP TRAY (2)**

The filter traps fatty vapours. It must be cleaned after approximately 30 hours of use or at least once a month. Use a soft brush, hot water and mild detergent. Rinse and dry it thoroughly before returning it to the hood.

- Lift and hold the the door.
- Unclip the cartridge filter by pressing downward.
- Remove the fat drip tray (2) by lifting it upwards.

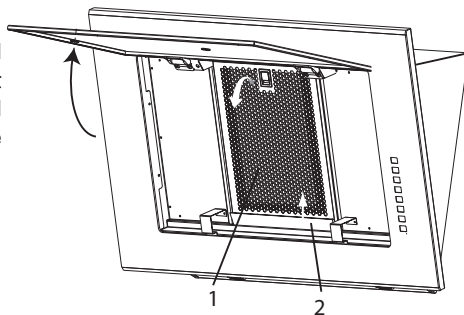

• **CHANGING THE CARBON FILTER (3)**

The filter traps cooking smells and must be replaced every 120 hours of use. Order these filters at your retailer.

- Remove the carbon filter by unclipping it.
- Dismantle the filter cartridge
- Remove the 2 metal attachment brackets (4)
- Remove the carbon filter from the filter cartridge
- Place the new filter in the filter cartridge
- Reposition the 2 attachment brackets
- Refit the filter cartridge

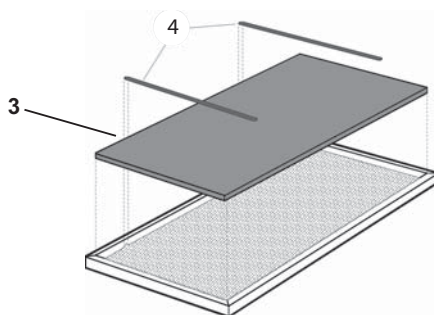

• **CLEANING THE OUTER SURFACES**

To clean the outside of your hood, use soapy water, rinse with fresh water then wipe with a soft cloth (do not use abrasive creams, scouring sponges or metal scouring pads).

• **CHANGING A BULB**

Model with halogen bulb (4)

- Remove the lamp glass
- Change the G4-20W-12V halogen bulb.
- Re-assemble by repeating these steps in reverse order.

Model with LED bulb

- Contact after-sales service

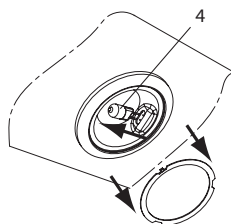

SYMPTOMS	SOLUTIONS
The hood is not working...	Ensure that: <ul style="list-style-type: none"> • The power is not cut off. • A speed has been selected.
The hood is not operating effectively...	Ensure that: <ul style="list-style-type: none"> • The selected motor speed is sufficient for the quantity of smoke and vapours to be cleared. • The kitchen is sufficiently ventilated to allow for fresh air intake. • The carbon filter is not worn (hood operating in recycling mode).
The hood stopped working	Ensure that: <ul style="list-style-type: none"> • The power is not cut off. • The single-pole cut-off device has not been activated.

To maintain your appliance in good condition, we recommend that you use Clearit cleaning products.



**Professional expertise
working for you at home**

Clearit offers professional products and solutions suited to the daily care of your kitchen and household appliances.

You will find them at your usual retailer, along with a complete range of accessories and consumables.

Any repair made to your appliance must be carried out by a qualified professional, authorised to work on the brand. When you call, state your appliance's complete reference information (model, type, serial number). This information appears on the manufacturer's nameplate (Fig. 1).

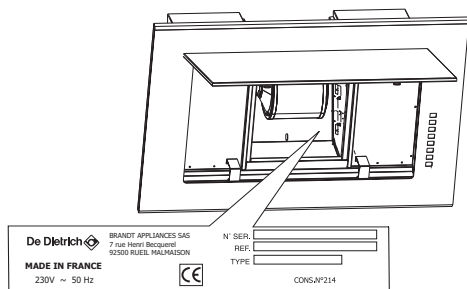

ORIGINAL PARTS

During maintenance work, request the exclusive use of **certified genuine replacement parts**.



CZ5700919_01 - 09/11