

SC12F70 Series

Vacuum Cleaner user manual

- ※ Please read the User Manual thoroughly before operating the vacuum.
- ※ For indoor use only.

English

imagine the possibilities

Thank you for purchasing a Samsung product.
To receive a more complete service,
please register your product at
www.samsung.com/register

SAMSUNG

Contents

YOUR VACUUM CLEANER

06

BEFORE USING THE VACUUM CLEANER

07

- 07 Assembly
- 08 Installing the dust sensor (SC12F70H Series)
- 08 Using accessory

OPERATING CLEANER

11

- 11 Power cord
- 11 Check filter
- 11 On/Off
- 12 Power control
- 13 Power brush (SC12F70P Series)
- 14 Dust sensor (SC12F70H Series)

MAINTENANCE

15

- 15 Cleaning the dust bin and grille
- 18 Cleaning the outlet filter
- 19 Power brush (SC12F70P Series)

TROUBLESHOOTING

23

Safety information

SAFETY INFORMATION



- Before operating the appliance, please read this manual thoroughly and retain it for your reference.



- Because the following operating instructions cover various models, the characteristics of your vacuum cleaner may differ slightly from those described in this manual.

CAUTION/WARNING SYMBOLS USED

	Indicates that a risk of death or serious injury exists.
	Indicates that a risk of personal injury or material damage exists.

OTHER SYMBOLS USED

	Represents something you must NOT do.
	Represents something you must follow.
	Indicates that you must disconnect the power plug from the socket.



This vacuum cleaner is designed for household use only.

Do not use this vacuum cleaner to clean building waste or debris.

Regularly keep the filters in clean conditions to prevent of collecting fine dust in them.

Do not use this vacuum cleaner with any of the filters removed.

Failure to meet these requirements could cause injury, damage the vacuum cleaner and void your warranty.

IMPORTANT SAFETY INSTRUCTIONS

When using an electrical appliance, you should always follow these basic precautions:

READ ALL INSTRUCTIONS BEFORE USING YOUR CANISTER VACCUM

WARNING – TO REDUCE THE RISK OF FIRE, ELECTRIC SHOCK, OR INJURY:

1. Do not leave the appliance unattended when it is plugged in. Unplug from the outlet when not in use and before servicing.
2. Do not use outdoors or on wet surfaces.
3. Do not allow the vacuum to be used as a toy. Pay close attention when the vacuum is used by or near children.
4. Use only as described in this manual. Use only manufacturer's recommended attachments.
5. Do not use with a damaged cord or plug. If the appliance is not working as it should, has been dropped, damaged, left outdoors, or dropped into water, bring it to a service center.
6. Do not pull or carry by the cord, use the cord as a handle, close a door on the cord, or pull the cord around sharp edges or corners. Do not run appliance over the cord. Keep the cord away from heated surfaces.
7. Do not unplug by pulling on the cord. To unplug, grasp the plug, not the cord.
8. Do not handle the plug or appliance with wet hands.
9. Do not put any object into openings. Do not use with any opening blocked. Keep free of dust, lint, hair, and anything that may reduce air flow.
10. Keep hair, loose clothing, fingers, and all parts of your body away from openings and moving parts.
11. Turn off all controls before unplugging.
12. Use extra care when cleaning on stairs.
13. Do not use to pick up flammable or combustible liquids, such as gasoline, or use in areas where they may be present.
14. Do not pick up anything that is burning or smoking, such as cigarettes, matches, or hot ashes.
15. Do not use without the dirt cup and/or filters in place.
16. Do not use the vacuum cleaner in an enclosed space filled with vapors given off by oil base paint, paint thinner, some moth proofing substances, flammable dust, or other explosive or toxic materials.
17. Do not pick up hard or sharp objects such as glass, nails, screws, coins, etc.
18. The hose contains electrical wires. Do not use when damaged, cut, or punctured. Avoid picking up sharp objects.
19. Always turn off this appliance before connecting or disconnecting either the hose or motorized nozzle.

20. Unplug before connecting the motorized nozzle.

21. Hold the plug when rewinding onto the cord reel. Do not allow the plug to whip when rewinding.

SAVE THESE INSTRUCTIONS

POLARIZED PLUG INSTRUCTIONS

- To reduce the risk of electric shock, this appliance has a polarized plug (one blade is wider than the other). This plug will fit in a polarized outlet only one way. If the plug does not fit fully in the outlet, reverse the plug. If it still does not fit, contact a qualified electrician to install the proper outlet. Do not change the plug in any way.

State of california proposition 65 warning (US only)



This product contains chemicals known to the State of California to cause cancer and reproductive toxicity.

Your vacuum cleaner

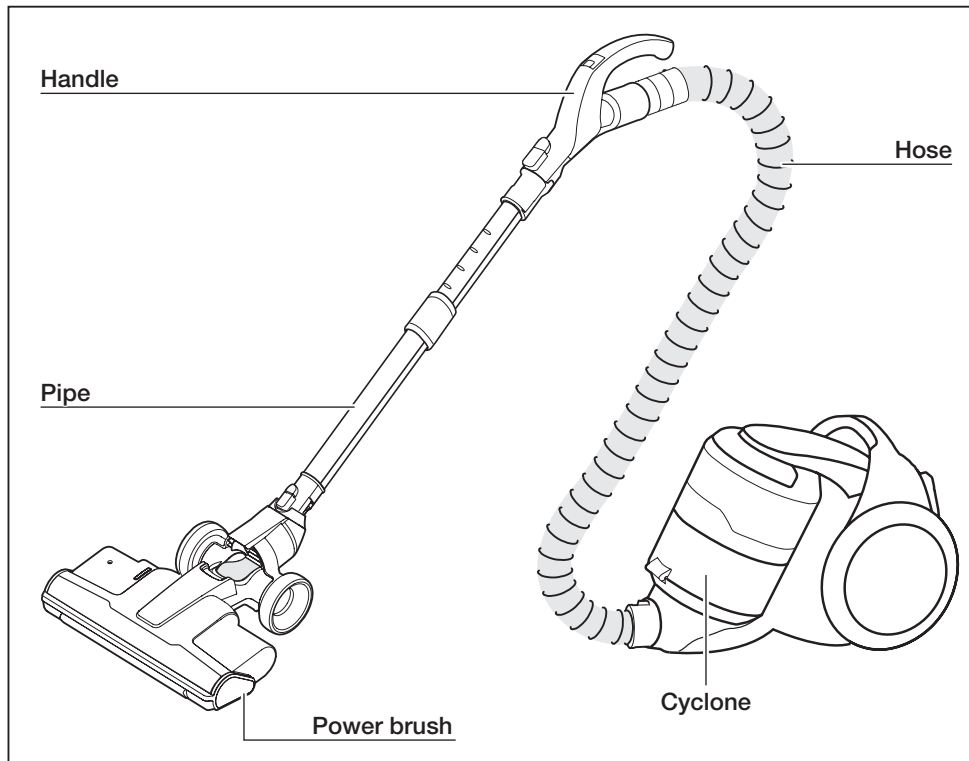

OPTION (SC12F70P Series)

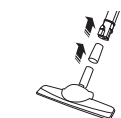

Parquet



Blanket brush



Cover battery



2-in-1 accessory

SC12F70H Series



Pipe*



Handle*



Power turbo plus*



2-Step brush*

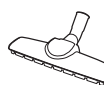

Parquet master*



Dust sensor*

Before using the vacuum cleaner

ASSEMBLY

Connecting the hose

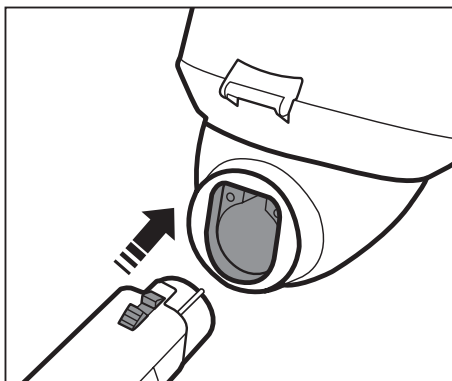

Connecting the handle and pipe

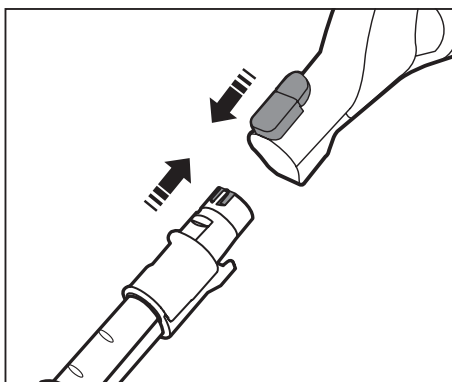

Connecting the brush

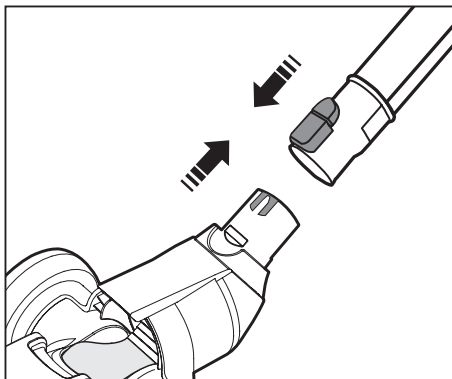

INSTALLING THE DUST SENSOR (SC12F70H Series)

Assemble the dust sensor

between the brush and the pipe
between the pipe and the hose

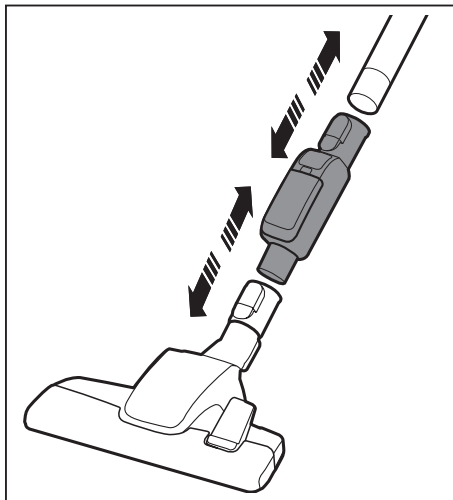

USING ACCESSORY

Accessories (SC12F70P Series)

Install the accessory to the handle.

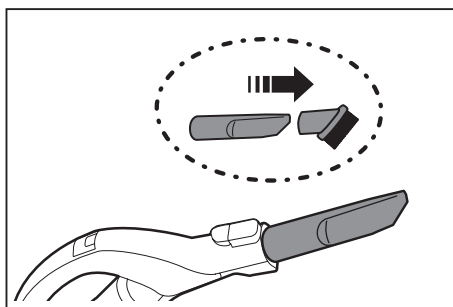

Dusting brush - For cleaning moldings, carved articles. etc.
Crevice tool - For cleaning in folds, crevices and corners.

Combination accessory (SC12F70H Series)

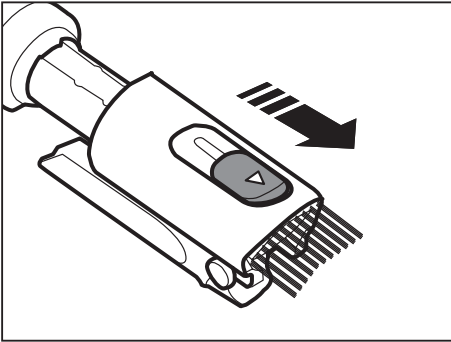
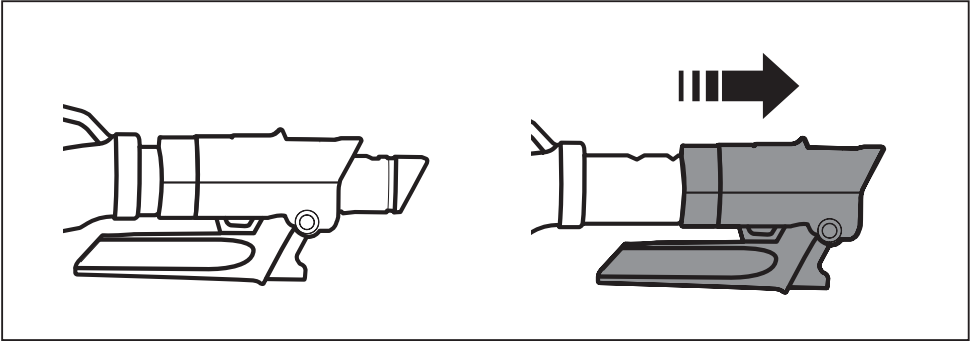

Dusting brush

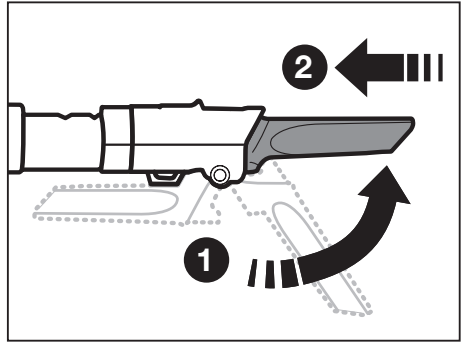

Crevice tool

Pipe

Adjust the length of the pipe by sliding the length control button located in the center of the telescopic pipe.

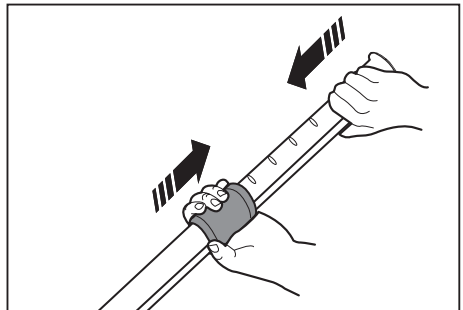

For storage, park the floor nozzle (SC12F70H Series)

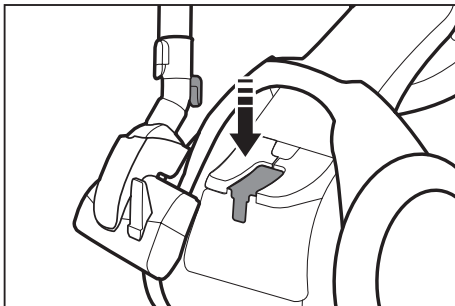

Do not pick up a machine while the floor nozzle parked.

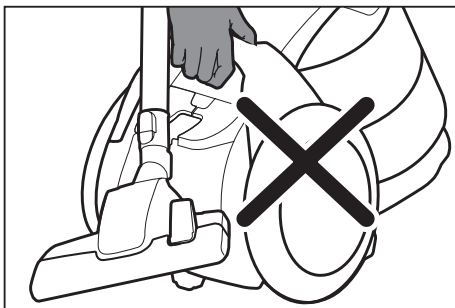

For storage, upright the pipe on the floor (SC12F70P Series)

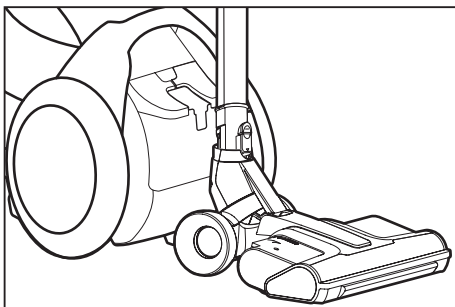

Operating cleaner

POWER CORD

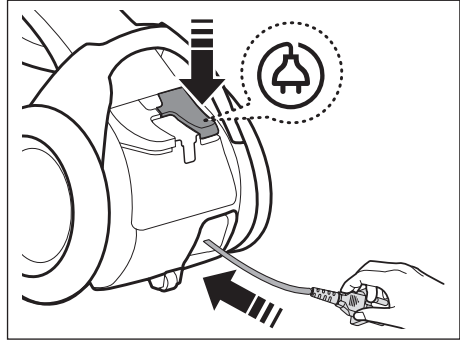
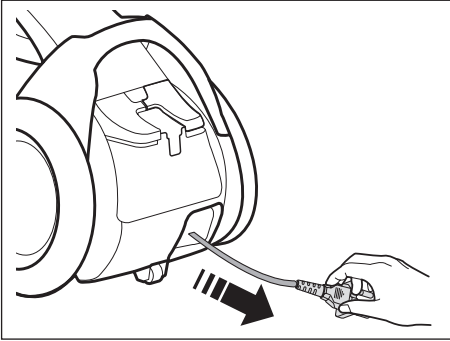

When removing the plug from the electrical outlet, grasp the plug, not the cord.

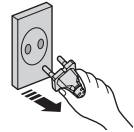

CHECK FILTER

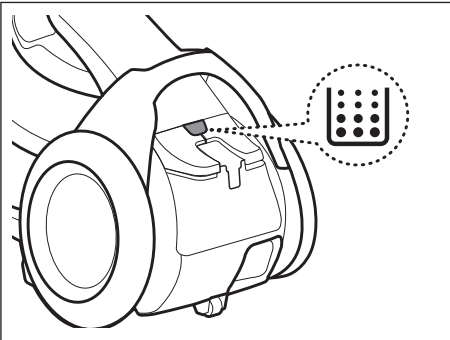

ON/OFF

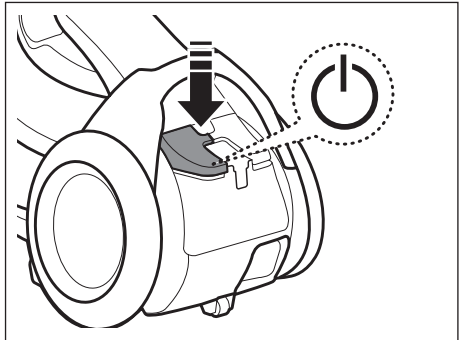

The filter light is illuminated when the dust pack requires checking or emptying.

POWER CONTROL

Hose (controlled by radio frequency signals)



SC12F70P Series

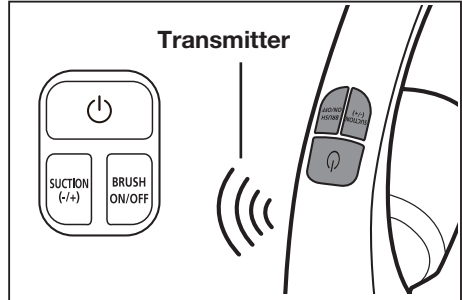
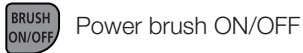
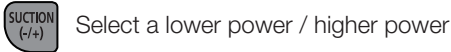

SC12F70H Series

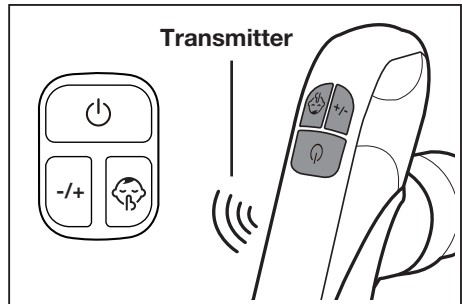

- Don't cover the handle transmitter when you use a handle control.



1. Never disassemble or recharge the batteries.
2. Never heat up the batteries or throw them into a fire.
3. Do not reverse (+), (-) poles.
4. Dispose of the batteries properly.

BATTERY TYPE : AAA Size

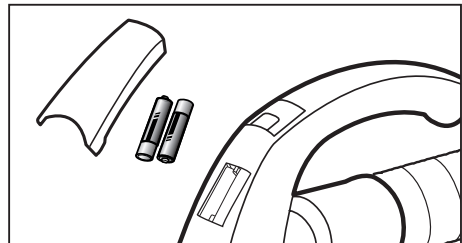

FCC NOTICE / FCC ID : A3LROH20S

This device complies with part 15 of the FCC Rules. Operation is subject to the following two conditions:

1. This device may not cause harmful interference, and
2. This device must accept any interference received, including interference that may cause undesired operation.

POWER BRUSH (SC12F70P Series)

Vacuuming with the power brush

1. Attaching the power brush

- The hose must be plugged into the canister and the power brush must be plugged into the hose and extension wand.

2. Vacuuming

- For best results, move the power brush slowly using short, overlapping strokes.
- For heavily soiled areas, repeat strokes in several directions.

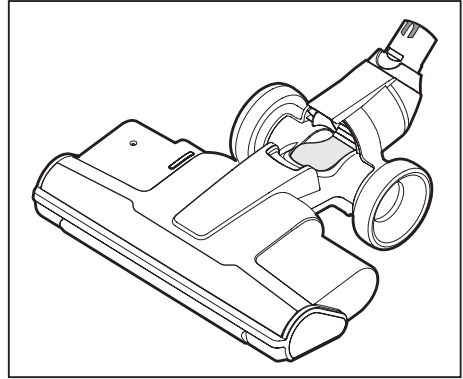

Do not invert the power brush while it is running.

3. Checking the performance of the power brush

You can check whether the power brush is operating correctly by lifting up the extension tube slightly to view the back of the brush.

The power brush will not operate when it is jammed or the unit is turned off.

If the power brush is jammed, unplug the power cord from the electrical outlet.

Turn the power brush over and remove the jammed object.

Turn the power brush back to the vacuuming position and resume vacuuming.

Overload protector

The overload protector shuts off the brush motor if the floor brush becomes obstructed. The floor brush will stop, but the suction motor will continue to run. To reset the overload protector, turn the vacuum off and unplug it. Clear the obstruction from the floor brush area. Use a pen tip to press down the reset switch. Turn the vacuum on and continue cleaning.

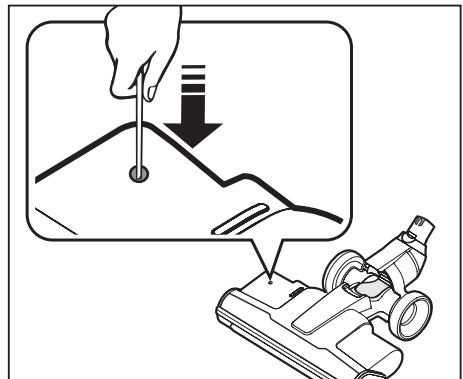

DUST SENSOR (SC12F70H Series)

Dust sensor operations

- Indicates the amount of dust being picked up and passing by the sensor which assist the user to clean more efficiently.
- The dust sensor is activated automatically when the cleaner runs and is turned off when the cleaner is stopped.



Green : Amount of dust passing sensor is small.

Red : Amount of dust passing sensor is large.

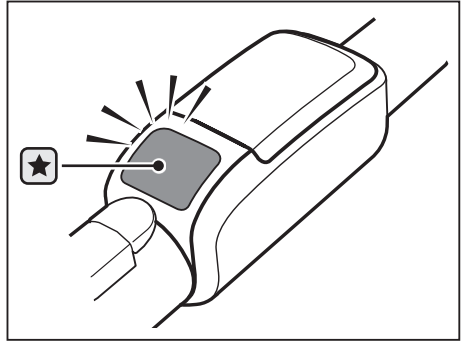

If the red light does not light up when cleaning a dusty location

- Clean the sensors (2EA) with a dry cloth.
- Take care when you use the cleaner because the dust sensor may malfunction or may break due to an impact.

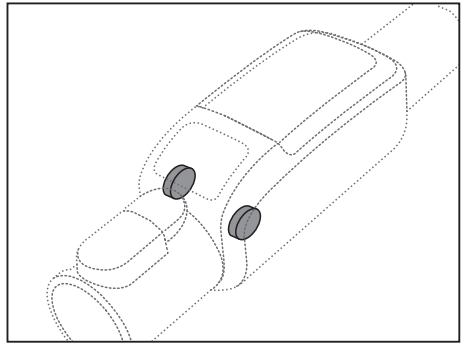

Installing the batteries

If the dust sensor does not work, change the batteries.

BATTERY TYPE : AAA Size 

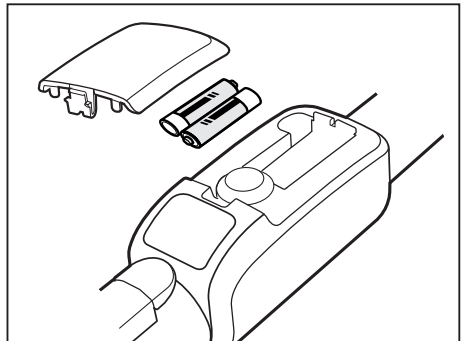

Maintenance

CLEANING THE DUST BIN AND GRILLE

Empty the dust bin, if dust reaches 'MAX' or Check filter () light is illuminating.

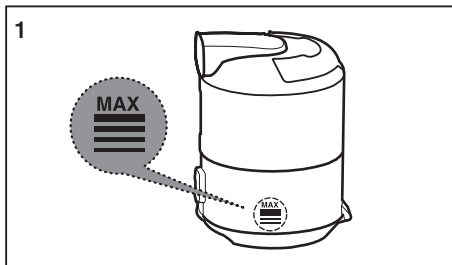

Take the dust bin out by lifting the handle.

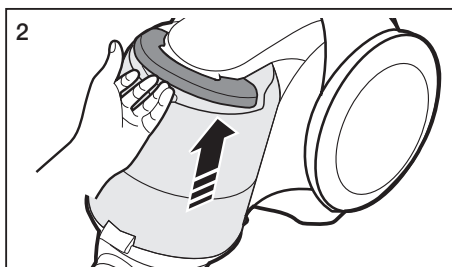

Push the button aside.

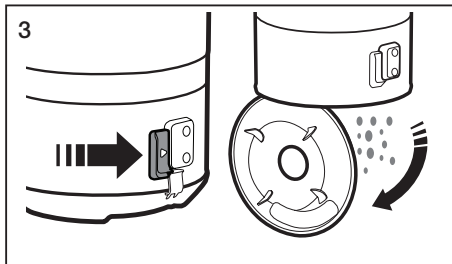

Turn the grille and take out it.

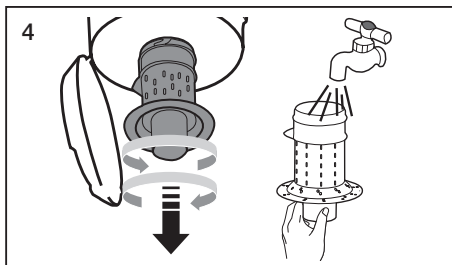

Push the button.
Separate the dust bin from body.

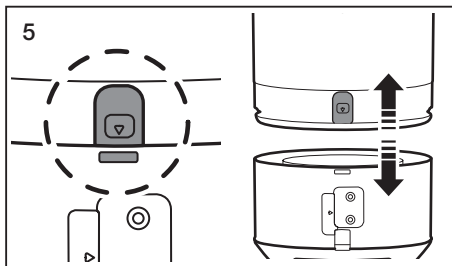

Clean the dust bin and body with water.

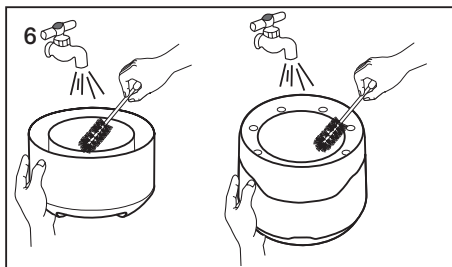

Leave the dust bin and body in the shade until completely dry.

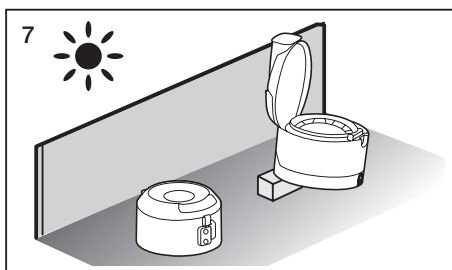

 Install the grille and turn to clockwise.

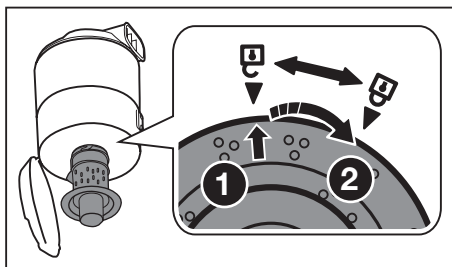

CLEANING THE DUST FILTER

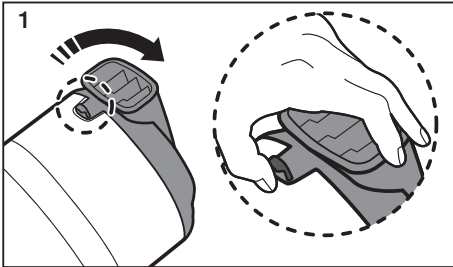

1 Pull the dust bin cover to open.

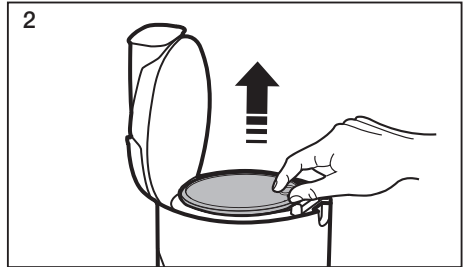

2 Remove the filter from the dust bin.

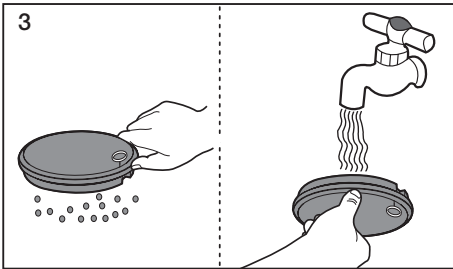

3 Shake the filter to remove dust, then wash the filter.

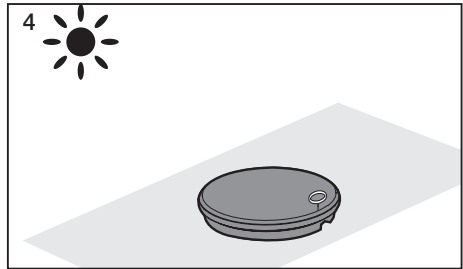

4 Let the filter dry for more than 12 hours.

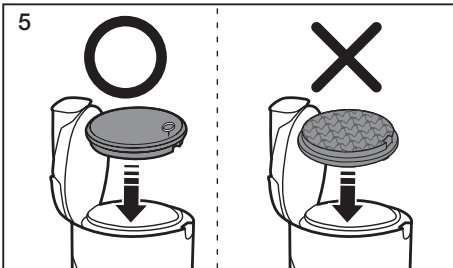

5 Put the filter into the dust bin.



Make sure the filter is completely dry before putting it back into the vacuum cleaner. Allow 12 hours for it to dry.

Do not use wet filter.

Replace the dust filter if it becomes damaged or deformed.

The dust bin cover will not close if the filter is not installed correctly.



CLEANING THE OUTLET FILTER

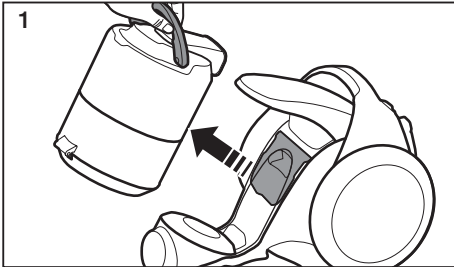

1 Take the dust bin out by lifting the handle.

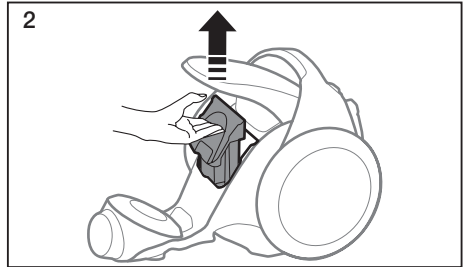

2 Pull out the HEPA Filter.

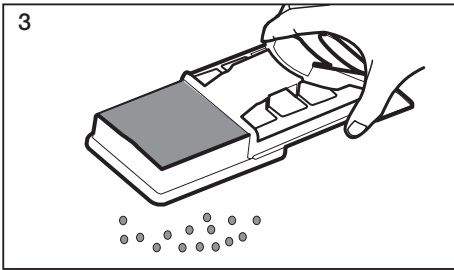

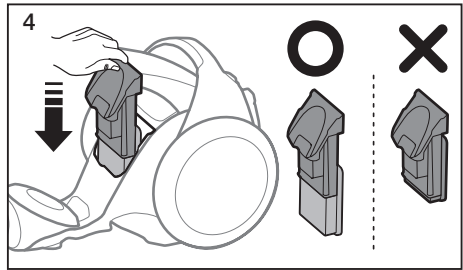

3 Shake the HEPA Filter to clean.

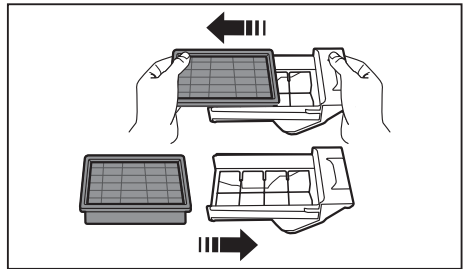

4 Install the filter and holder in main body.

-  • The filter can be replaced and separated from holder by pulling.



-  • Clean the outlet filter when suction is noticeably reduced continuously or the vacuum cleaner abnormal overheads.
Note: HEPA Filters are not washable.
Replace filter if cleaning does not resolve the problem.
- Recommend that HEPA Filter should be changed once in 6 month.

POWER BRUSH (SC12F70P Series)

Checking the rotating floor brush and drive belt

You should check your vacuum cleaner's rotating floor brush and drive belt regularly for wear or damage. You should also clean strings, hair, and carpet fibers off the brush and brush ends. These can wrap around the brush and hamper its ability to effectively clean your carpet. Also remove any debris that has accumulated under the brush cover.

1. Unplug the vacuum from the electrical outlet.
2. Place the handle in low position and turn the vacuum cleaner over so the bottom side is up.
3. Remove the five screws (at arrows, right) with a screwdriver.
4. Remove the brush cover from the floor brush.
5. Grasp the rotating floor brush at both ends and lift.
6. Clean string, hair and other debris off the rotating floor brush, paying particular attention to brush ends.
7. Clean string, hair and other debris off the motor pulley and drive belt areas.
8. Check the drive belt carefully for wear, cuts or stressed areas.
9. Check the air passageway for obstructions. Remove debris from this area.



CAUTION

The rotating floor brush could cause the fringe of a rug to become tangled within the vacuum.

Use caution and turn off the floor brush when vacuuming throw rugs with fringe.

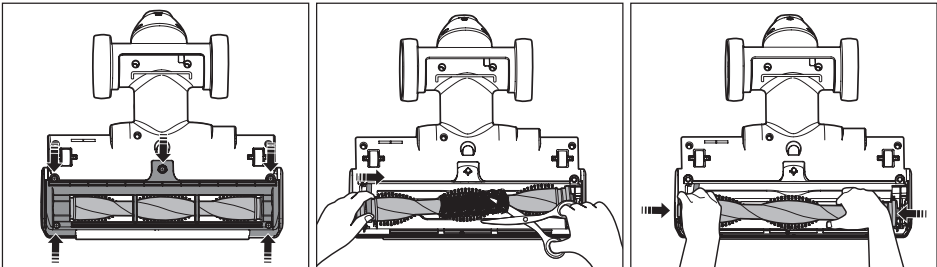

2-step brush (SC12F70H Series)

- Adjust the inlet lever according to the floor surface.



Carpet



Floor

- Remove waste matter completely if the inlet is blocked.

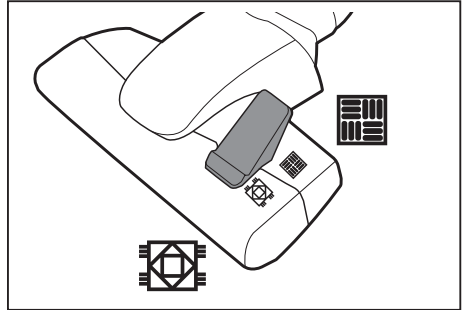

Parquet brush (SC12F70P Series)

- Vacuums dust in a wide area at once.
- Remove waste matter completely from the inlet if the inlet is blocked.

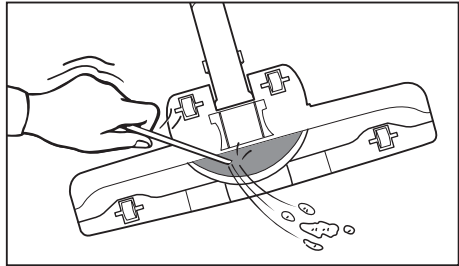
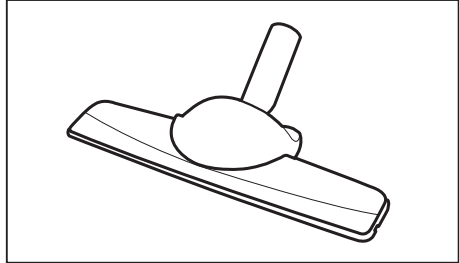

Blanket brush (SC12F70P Series)

- Remove waste matter completely when inlet is blocked.
- Turn the lock button to (🔒), and remove.
- To reassemble, align the cover to the front of the main body and close. After closing the cover, ensure that the lock button is turned to the (🔒) position.

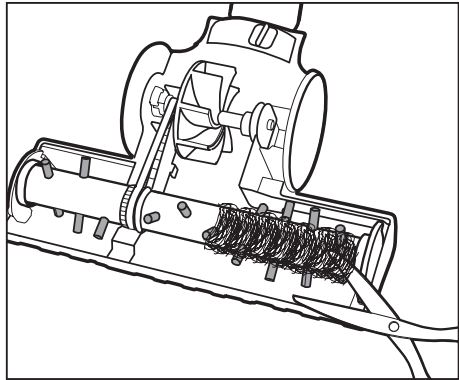
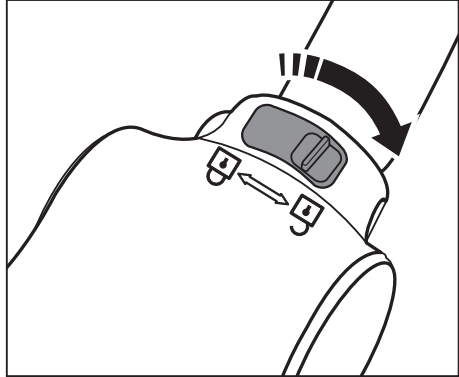

Use for bedclothes only. Be careful not to damage the brush during unclogging.

Troubleshooting

PROBLEM	SOLUTION
Motor does not start.	<ul style="list-style-type: none">• Check cable, plug and socket.• Leave to cool.
Suction force is gradually decreasing.	
In operation, the vacuum cleaner stops after repeating runs and stops three times.	<ul style="list-style-type: none">• Check for blockage and remove.• Please unclog the intake.
Cord does not rewind fully.	<ul style="list-style-type: none">• Pull the cord out 2-3 m and push down the cord rewind button.
Vacuum cleaner does not pick up dirt.	<ul style="list-style-type: none">• Check hose and replace if required.
Low or decreasing suction.	<ul style="list-style-type: none">• Please check filter and, if required, clean as illustrated in the instructions. If filters are out of condition change them to new ones.
Body overheating.	<ul style="list-style-type: none">• Please check filters, if required clean as illustrated in the instruction.
Static electricity discharge.	<ul style="list-style-type: none">• Please decrease power suction.• This can also occur when air in the room is very dry. Please ventilate the room till air humidity becomes normal.
The vacuum cleaner makes a strange noise.	<ul style="list-style-type: none">• In order to protect the motor in the cleaner, it rotates slowly when you just turn on the cleaner. (Before the motor stabilizes,) this causes the loud noise at the initial state and it is not failure in the machine.



Série SC12F70

Aspirateur manuel d'utilisation

- ※ Avant d'utiliser l'aspirateur, lisez attentivement le manuel d'utilisation.
- ※ Utilisation intérieure uniquement.

Français

imagine the possibilities

Merci d'avoir choisi un produit Samsung.
Afin de bénéficier d'un service plus complet,
veuillez enregistrer votre produit à l'adresse
www.samsung.com/register

SAMSUNG

Sommaire

VOTRE ASPIRATEUR

06

AVANT D'UTILISER L'ASPIRATEUR

07

- 07 Montage
- 08 Installation du capteur de poussière (Série SC12F70H)
- 08 Utilisation des accessoires

UTILISATION DE L'ASPIRATEUR

11

- 11 Cordon d'alimentation
- 11 Vérification du filtre
- 11 Marche/Arrêt
- 12 Contrôle de la puissance
- 13 Brosse motorisée (Série SC12F70P)
- 14 Capteur de poussière (Série SC12F70H)

MAINTENANCE

15

- 15 Nettoyage du réservoir à poussière et du support de grille
- 18 Nettoyage du filtre de sortie
- 19 Brosse motorisée (Série SC12F70P)

DÉPANNAGE

23

Consignes de sécurité

CONSIGNES DE SÉCURITÉ



- Avant d'utiliser cet appareil, veuillez lire attentivement ce manuel et le conserver pour toute référence ultérieure.



- Les instructions d'utilisation suivantes concernent plusieurs modèles ; il est donc possible que les caractéristiques de votre aspirateur soient légèrement différentes de celles spécifiées dans ce manuel.

SYMBOLES ATTENTION/AVERTISSEMENT UTILISÉS

	Indique un risque de blessures graves ou mortelles.
	Indique un risque de blessure ou de dégât matériel.

AUTRES SYMBOLES UTILISÉS

	Indique une action INTERDITE.
	Indique une action que vous devez effectuer.
	Indique que vous devez débrancher la fiche d'alimentation de la prise.



- Cet aspirateur est destiné à une utilisation domestique uniquement.
Ne l'utilisez pas pour le nettoyage de saletés ou débris provenant de la construction.
Maintenez les filtres régulièrement propres afin d'éviter l'infiltration de toute poussière fine.
N'utilisez pas cet aspirateur lorsque l'un des filtres a été retiré.

Le non-respect de ces consignes peut provoquer des blessures, endommager l'aspirateur et annuler la garantie.

CONSIGNES IMPORTANTES DE SÉCURITÉ

Lors de l'utilisation d'un appareil électrique, suivez toujours ces précautions de base :

LISEZ TOUTES LES INSTRUCTIONS AVANT D'UTILISER VOTRE ASPIRATEUR TRINEAU

AVERTISSEMENT – POUR LIMITER TOUT RISQUE D'INCENDIE, D'ÉLECTROCUTION OU DE BLESSURE :

1. Ne laissez pas l'appareil sans surveillance lorsqu'il est branché.
Débranchez-le lorsque vous ne l'utilisez pas ou avant toute opération d'entretien.
2. N'utilisez pas l'appareil à l'extérieur ni sur des surfaces mouillées.
3. Cet aspirateur ne doit pas être utilisé comme un jouet. Prêtez une attention particulière aux enfants qui vous entourent lorsque vous utilisez l'aspirateur.
4. Utilisez cet appareil uniquement tel qu'indiqué dans le présent manuel. Utilisez des accessoires recommandés par le fabricant uniquement.
5. N'utilisez jamais de cordon ou de prise endommagé(e).
Si l'appareil fonctionne anormalement, a reçu un choc, a été endommagé, laissé à l'extérieur ou plongé dans l'eau, retournez-le au centre d'assistance.
6. Ne tirez pas sur le cordon ; ne soulevez pas l'appareil par le cordon ; n'utilisez pas le cordon comme poignée ; ne fermez pas de porte sur le cordon ; ne tirez pas le cordon sur des rebords ou des angles coupants.
Ne placez pas l'appareil sur le cordon.
Maintenez le cordon éloigné des surfaces chauffées.
7. Ne débranchez pas l'appareil en tirant sur le cordon.
Pour débrancher, tenez la prise et non le cordon.
8. Ne manipulez pas la prise ou l'appareil si vous avez les mains mouillées.
9. N'insérez aucun objet dans les ouvertures.
N'utilisez pas l'appareil si l'une des ouvertures est obstruée.
Nettoyez régulièrement les ouvertures pour éliminer toute trace de poussière, peluches, cheveux, ou toute autre chose risquant d'empêcher le passage de l'air.
10. Maintenez les cheveux, les vêtements larges, les doigts et toute autre partie de votre corps loin des ouvertures et des pièces en mouvement.
11. Mettez hors tension tous les contrôles avant de débrancher l'appareil.
12. Soyez très prudent lorsque vous nettoyez les escaliers.
13. N'aspirez jamais de liquides inflammables ou combustibles tels que de l'essence et n'utilisez jamais l'appareil si de tels liquides risquent d'être présents.
14. N'aspirez jamais d'objets en train de brûler ou de fumer, tels que des cigarettes, des allumettes ou des cendres chaudes.
15. N'utilisez pas l'aspirateur si le bac à poussière et/ou les filtres ne sont pas à leur place.
16. N'utilisez pas l'aspirateur dans un espace clos rempli de vapeurs de peinture à l'huile, de diluant, de substances antimites, de poussières inflammables et autres éléments explosifs ou toxiques.

17. N'aspirez jamais d'objets pointus ou tranchants tels que des morceaux de verres, des clous, des vis, des pièces de monnaie, etc.
18. Le tuyau contient des câbles électriques.
Ne l'utilisez pas s'il est endommagé, coupé ou percé.
N'aspirez pas d'objets pointus.
19. Mettez toujours cet appareil hors tension avant de connecter ou déconnecter le tuyau ou le suceur motorisé.
20. Débranchez l'appareil avant de connecter le suceur motorisé.
21. Tenez la fiche lorsque vous rembobinez le cordon afin d'éviter qu'il ne vous blesse.

CONSERVEZ CE MANUEL D'UTILISATION

INSTRUCTIONS DES PRISES POLARISÉES

- Pour limiter les risques d'électrocution, cet appareil dispose d'une prise polarisée (une broche est plus large que l'autre). Cette prise ne doit s'insérer dans la prise murale polarisée que dans un seul sens. Si la prise ne s'enfonce pas entièrement dans la prise murale, retournez-la. Si elle ne s'enfonce toujours pas correctement, contactez un électricien qualifié pour faire installer une prise murale adéquate. Ne remplacez et ne modifiez jamais la prise.

Avertissement de la proposition 65 de l'état de californie (États-unis uniquement)



Ce produit contient des substances chimiques considérées par l'État de Californie comme étant cancérigène ou à l'origine de troubles de la reproduction.

Votre aspirateur

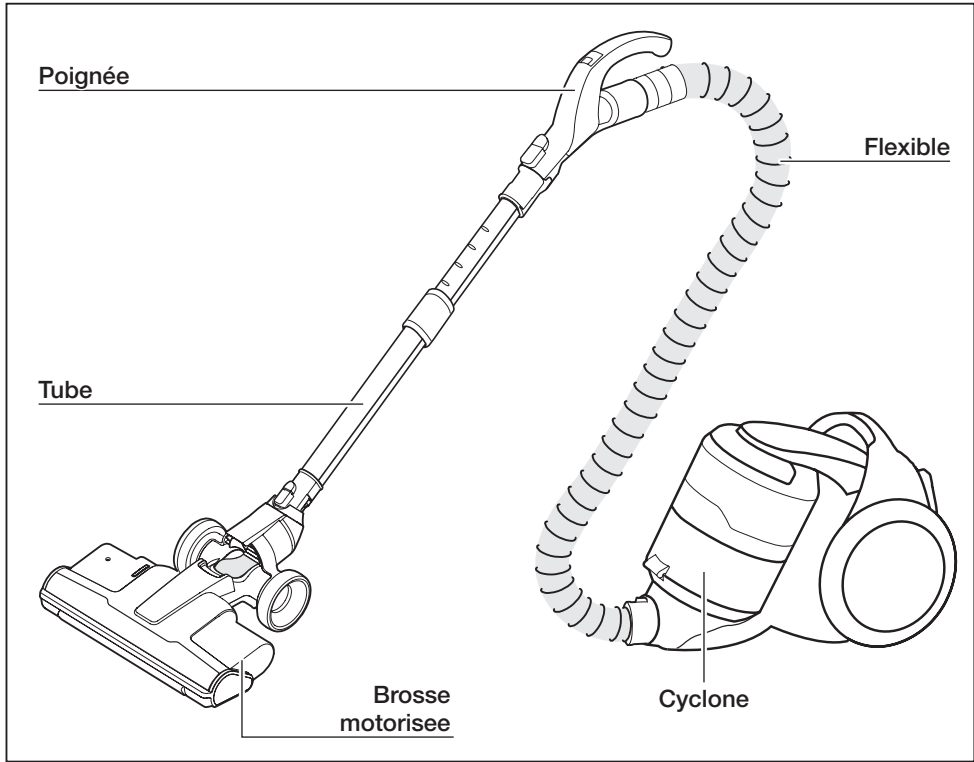

OPTION (Série SC12F70P)



Parquet



Brosse pour
couverture



Cache de la
batterie



Accessoire 2 en 1

Série SC12F70H



Tube *



Poignée *



Puissance Turbo
Plus *



Brosse 2
positions *

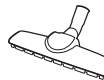

Brosse pour
parquet *



Capteur de
poussière *

Avant d'utiliser l'aspirateur

MONTAGE

Connexion du flexible

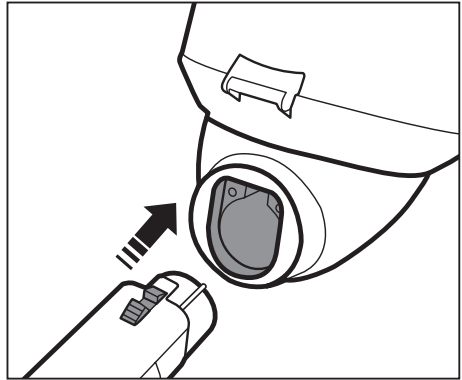

Connexion de la poignée et du tube

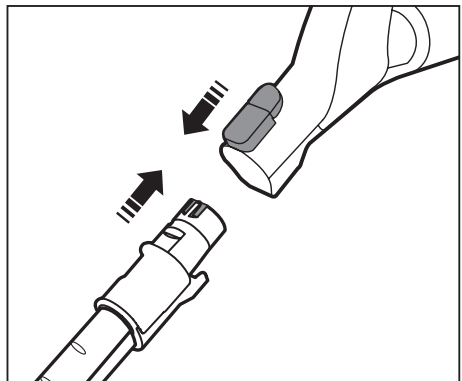

Connexion de la brosse

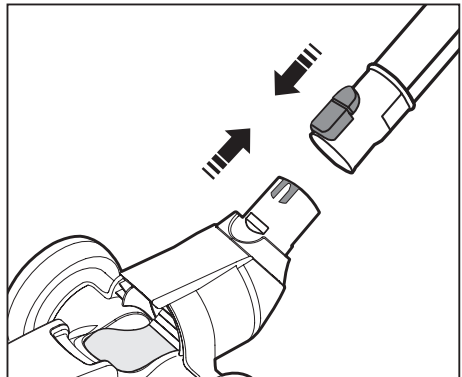

INSTALLATION DU CAPTEUR DE POUSSIÈRE (Série SC12F70H)

Placez le capteur de poussière

entre la brosse et le tube
entre le tube et le flexible

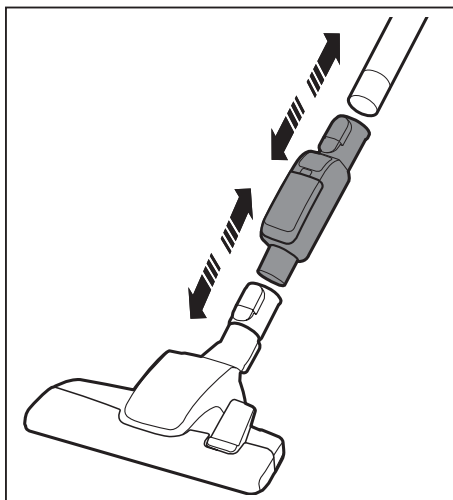

UTILISATION DES ACCESSOIRES

Accessoires (Série SC12F70P)

Installez l'accessoire au niveau de la poignée.

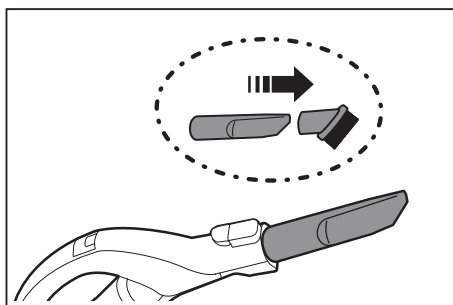

Brosse à épousseter - Pour nettoyer des articles moulés ou sculptés, etc.

Suceur plat - Pour nettoyer dans des plis, interstices et recoins.

Accessoire combiné (Série SC12F70H)

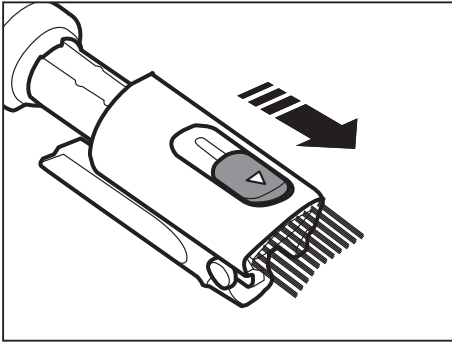
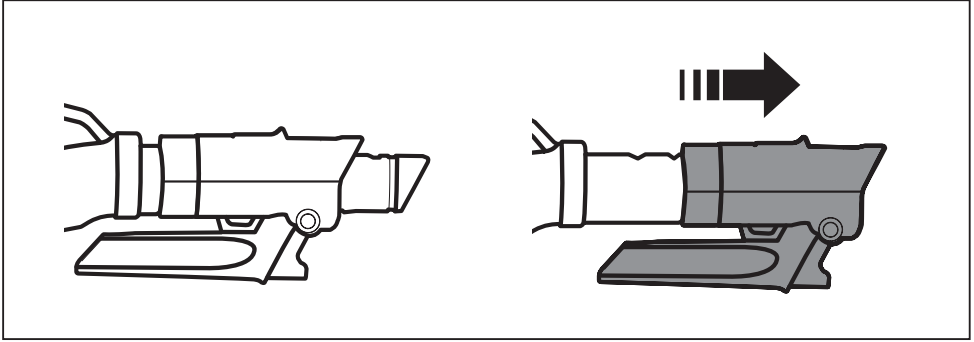

Brosse à épousseter

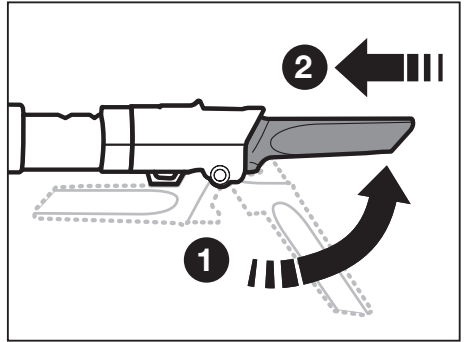

Suceur plat

Tube

Réglez la longueur du tube en faisant glisser le bouton de contrôle de la longueur situé au centre du tube télescopique.

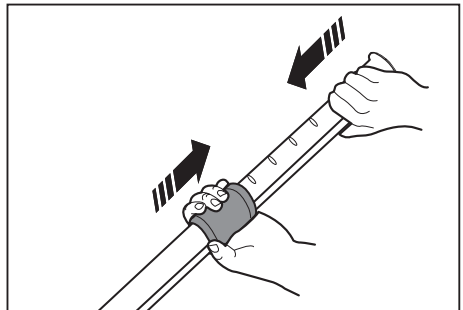

Avant d'entreposer l'aspirateur, fixez le suceur à parquets sur sa position de rangement. (SC12f70H Série)

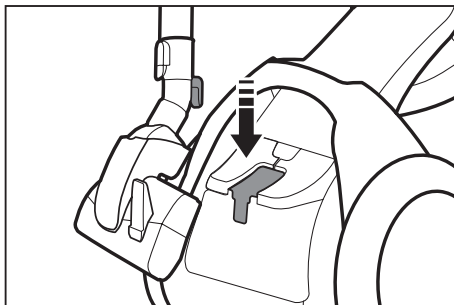

Ne soulevez pas l'aspirateur lorsque le suceur à parquets est fixé sur sa position de rangement.

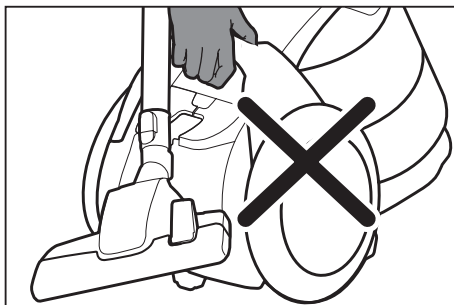

Pour le stockage, redresser le tuyau sur le sol (SC12F70P Série)

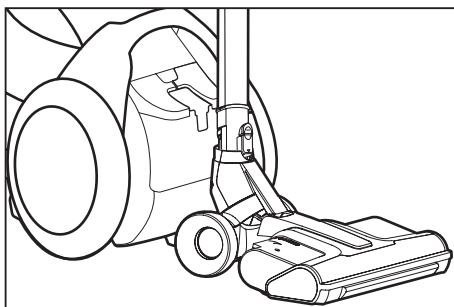

Utilisation de l'aspirateur

CORDON D'ALIMENTATION

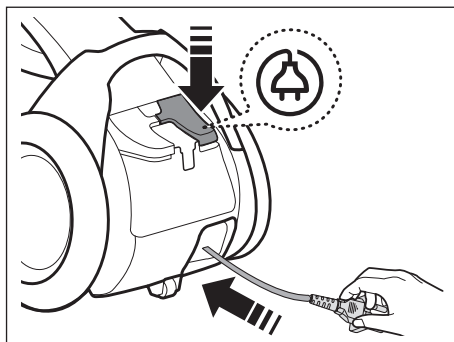
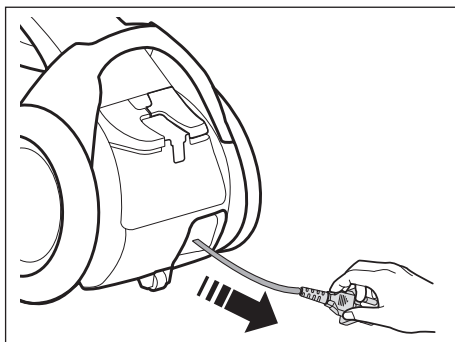

ATTENTION

Lorsque vous débranchez la fiche d'une prise électrique, tenez la fiche, non le cordon.

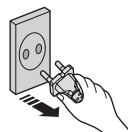

VÉRIFICATION DU FILTRE

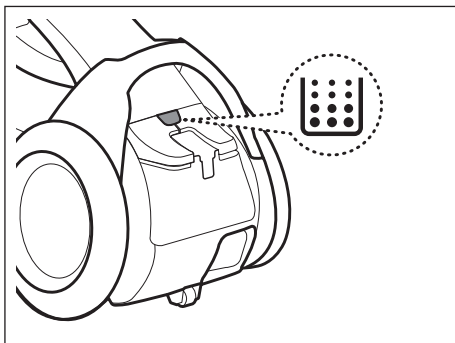

MARCHE/ARRÊT

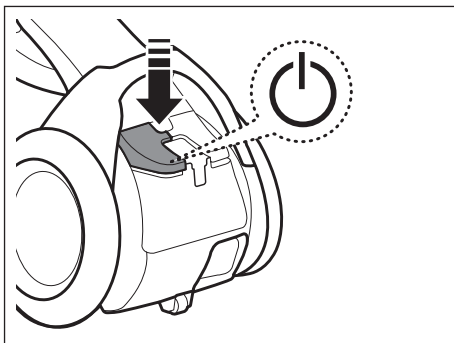

Le témoin du filtre s'allume lorsque le groupe filtrant doit être vérifié ou vidé.

CONTRÔLE DE LA PUISSANCE

Flexible (commandé par signaux radioélectriques)



Série SC12F70P

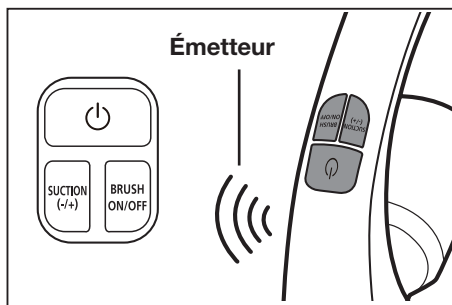

Série SC12F70H

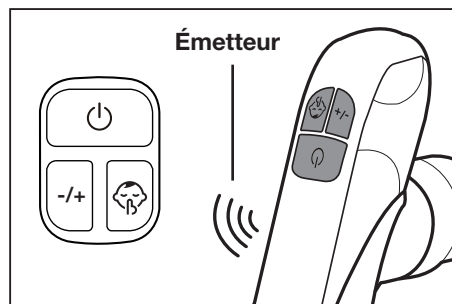
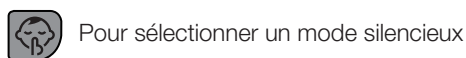

- Ne placez pas d'obstacle devant l'émetteur lorsque vous utilisez la commande sur la poignée.



ATTENTION

1. Ne démontez jamais les piles ni ne les rechargez pas.
2. N'exposez jamais les piles à la chaleur, ne les jetez jamais non plus dans le feu.
3. N'inversez pas les pôles (+) et (-).
4. Mettez les piles au rebut en respectant les règles en vigueur.

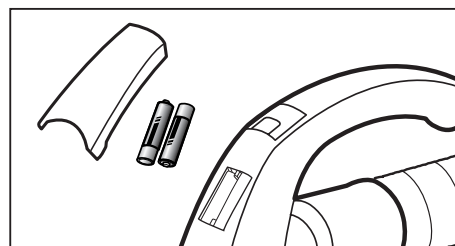

TYPE DE PILE : type AAA 

NORME FCC/FFC ID : A3LROH20S

Cet appareil est conforme à la section 15 des Règles de la FCC. Les deux conditions de fonctionnement suivantes sont requises :

1. Cet appareil ne doit pas provoquer d'interférence nocives et
2. Cet appareil doit accepter toute interférence reçue, même celles pouvant provoquer un fonctionnement indésirable.

BROSSE MOTORISEE (Série SC12F70P)

Aspiration avec la brosse motorisée

1. Fixation de la brosse motorisée

- Le tuyau doit être raccordé au traineau et la brosse motorisée doit être fixée au tuyau et au tube télescopique.

2. Aspiration

- Pour de meilleurs résultats, déplacez la brosse motorisée doucement sur des distances courtes et se chevauchant.
- Dans des zones très sales, passez l'aspirateur dans plusieurs sens.

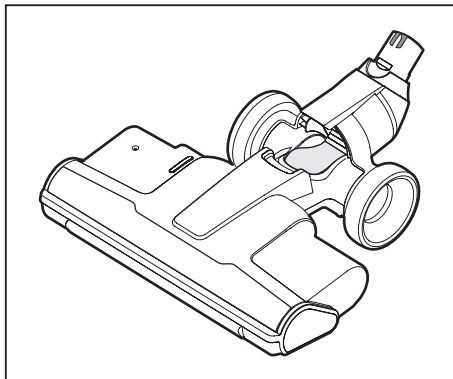

Ne retournez pas la brosse motorisée pendant son fonctionnement.

3. Vérification des performances de la brosse motorisée

Vous pouvez vérifier si la brosse motorisée fonctionne correctement en soulevant légèrement le tube d'extension pour voir la partie arrière de la brosse.

La brosse motorisée ne fonctionne pas lorsqu'elle est bouchée ou lorsque l'unité est hors tension.

Si la brosse motorisée est bouchée, débranchez le cordon d'alimentation de la prise électrique.

Retournez la brosse motorisée et retirez l'objet coincé.

Remettez la brosse motorisée en place et reprenez l'aspiration.

Protecteur contre surcharges

Le protecteur contre surcharges coupe le moteur de la brosse si la celle-ci devient bouchée. La brosse s'arrête, mais le moteur d'aspiration continue de fonctionner. Pour réinitialiser le protecteur contre surcharges, mettez l'aspirateur hors tension et débranchez-le. Retirez l'objet provoquant l'obstruction de la zone de la brosse. Utilisez un stylo pour appuyer sur le commutateur de réinitialisation. Activez l'aspirateur et continuez de l'utiliser.

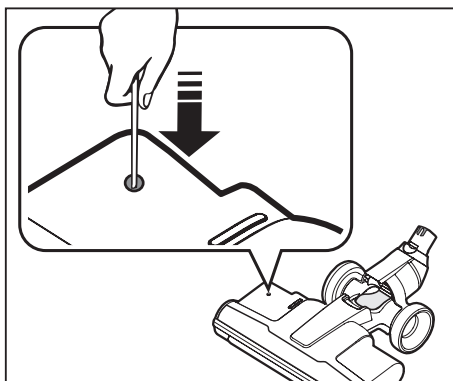

CAPTEUR DE POUSSIÈRE (Série SC12F70H)

Fonctionnement du capteur de poussière

- Indique la quantité de poussière qui est aspirée et passe devant le capteur, ce qui permet à l'utilisateur de nettoyer de manière plus efficace.
- Le capteur de poussière est active automatiquement lorsque l'aspirateur fonctionne et est éteint lorsque l'aspirateur est arrêté.



Vert : la quantité de poussière qui passe devant le capteur est faible.

Rouge : la quantité de poussière qui passe devant le capteur est importante.

Si la lumière rouge ne s'allume pas lorsque vous utilisez l'aspirateur dans une pièce poussiéreuse

- Nettoyez les capteurs (2 unités) à l'aide d'un chiffon sec.
- En cas de choc sur l'aspirateur, vérifiez toujours que le capteur de poussière n'a pas été endommagé et fonctionne correctement.

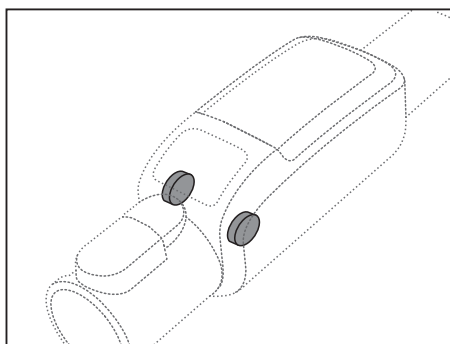
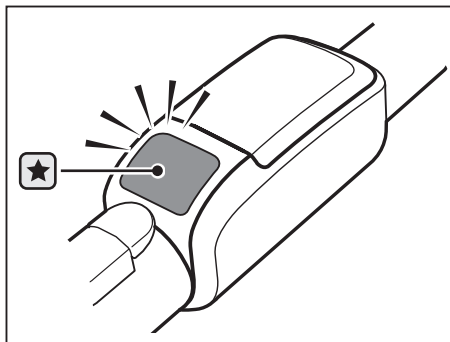

Mise en place des piles

Si le capteur de poussière ne fonctionne pas, remplacez les piles.

TYPE DE PILE : type AAA 

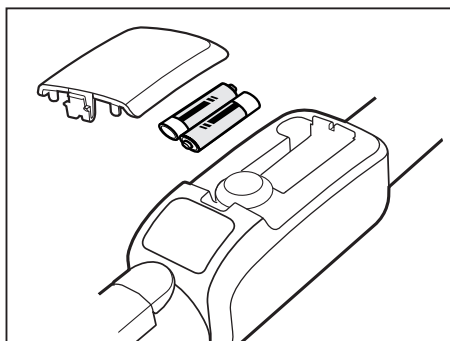

Maintenance

NETTOYAGE DU RÉSERVOIR À POUSSIÈRE ET DU SUPPORT DE GRILLE

Videz le réservoir de poussière lorsque la poussière atteint le repère « MAX » ou lorsque le symbole de vérification du filtre () s'allume.

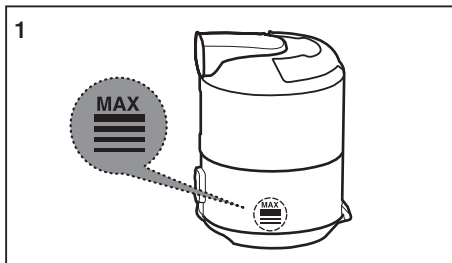

Pour extraire le réservoir à poussière, soulevez la poignée.

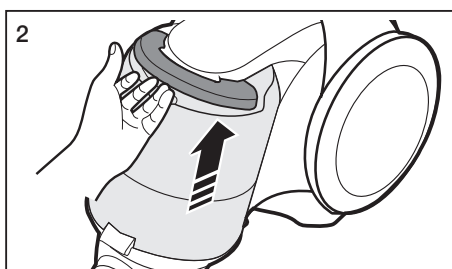

Faites glisser le bouton sur le côté.

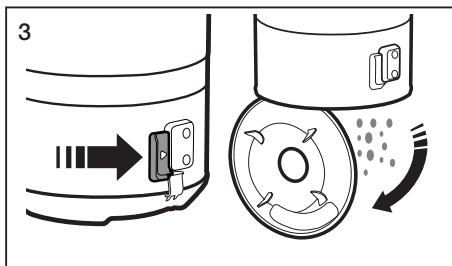

Faites tourner le support de la grille pour l'extraire.

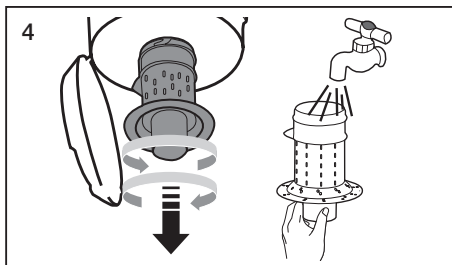

Appuyez sur le bouton.
Retirez le réservoir à poussière du corps.

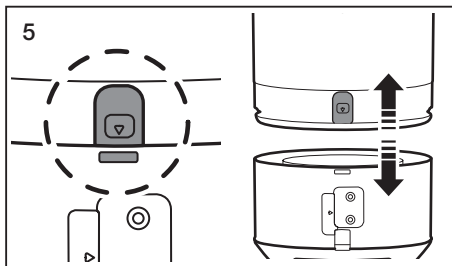

Nettoyez le réservoir à poussière et le corps
de l'aspirateur à l'eau claire.

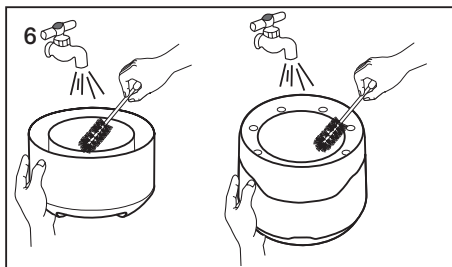

Laissez-les entièrement sécher à l'abri du soleil.

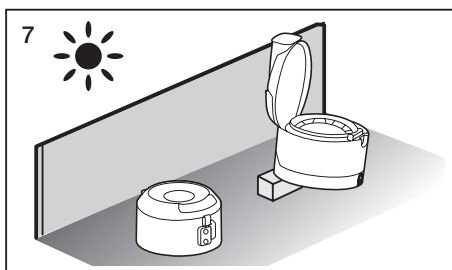

Insérez le support de grille et faites-le
tourner en sens horaire.

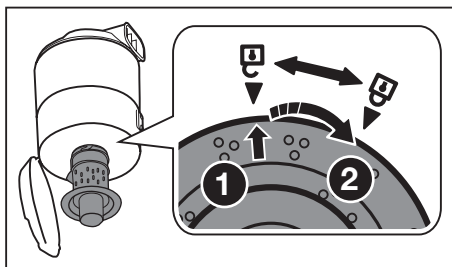

NETTOYAGE DU FILTRE À POUSSIÈRE

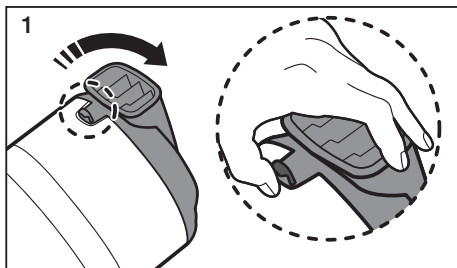

1 Tirez le couvercle du réservoir à poussière pour l'ouvrir.

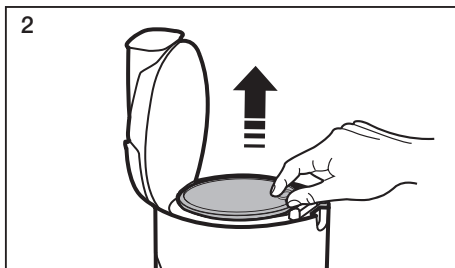

2 Retirez le filtre du réservoir à poussière.

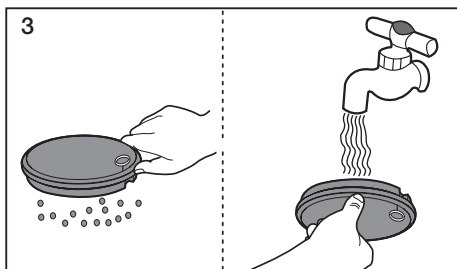

3 Secouez le filtre pour éliminer la poussière, puis lavez le filtre à l'eau claire.

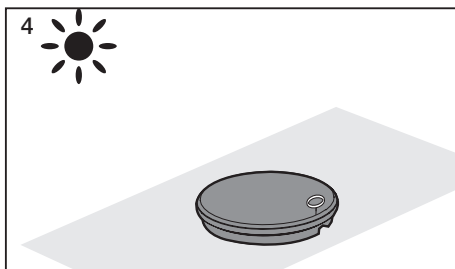

4 Laissez-le sécher pendant 12 heures minimum.

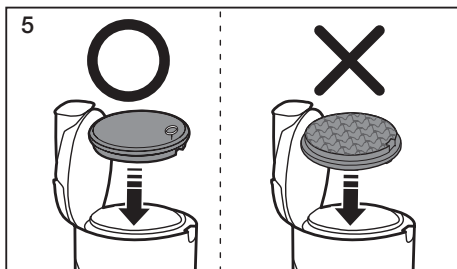

5 Remplacez le filtre dans le réservoir à poussière.



Veillez à ce que le filtre soit totalement sec avant de le replacer dans l'aspirateur. Laissez-le sécher pendant 12 heures.

N'utilisez pas un filtre mouillé.

Remplacez le filtre à poussière s'il est endommagé ou déformé.

Le couvercle du réservoir à poussière ne ferme pas si le filtre n'est pas installé correctement.



NETTOYAGE DU FILTRE DE SORTIE

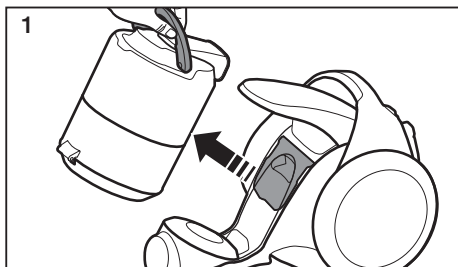

1 Pour extraire le réservoir à poussière, soulevez la poignée.

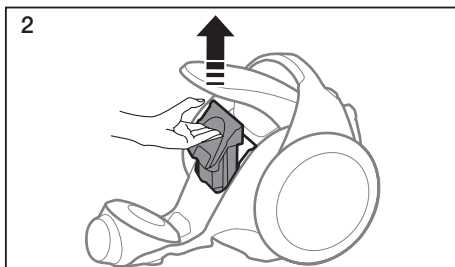

2 Tirez sur le filtre HEPA pour le retirer.

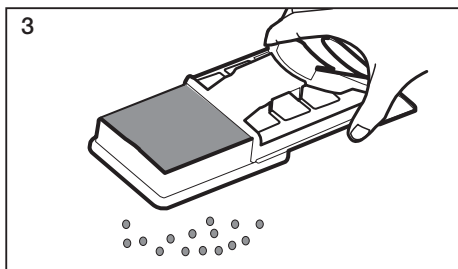

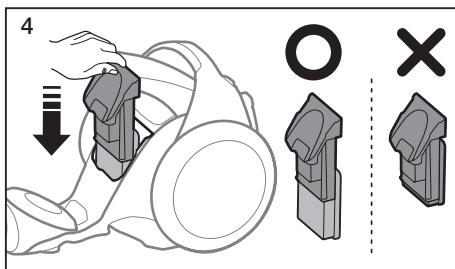

3 Secouez le filtre HEPA pour le nettoyer.

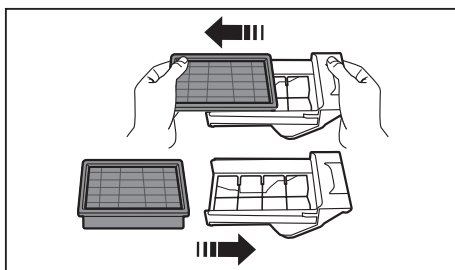

4 Remettez en place le filtre et son support dans le corps de l'aspirateur.

-  • Pour séparer le filtre de son support afin de le remplacer, tirez sur chacun des deux éléments.



-  • Lorsque la puissance d'aspiration est constamment réduite ou l'aspirateur surchauffe anormalement, nettoyez le filtre de sortie.
Remarque : Les filtres HEPA ne sont pas lavables.
Remplacez le filtre si son nettoyage ne résout pas le problème, .
- Nous vous conseillons de remplacer le filtre HEPA une fois tous les 6 mois.

Brosse motorisée (Série SC12F70P)

Vérification de la brosse rotative et de la courroie d'entraînement

Vous devez vérifier régulièrement si la brosse rotative et la courroie d'entraînement de votre aspirateur sont endommagées ou usées. En outre, vous devez nettoyer les ficelles, les cheveux et les fibres de moquette de la brosse et de ses extrémités. Ces éléments pourraient s'enrouler autour de la brosse et réduire la capacité de nettoyer efficacement votre tapis. Retirez également tous les débris accumulés sous le cache de la brosse.

1. Débranchez l'aspirateur de la prise électrique.
2. Placez la poignée sur la position inférieure et retournez l'aspirateur pour que la partie inférieure se situe en haut.
3. Retirez les five vis (au niveau des flèches du dessin à droite) à l'aide d'un tournevis.
4. Retirez le cache de la brosse.
5. Saisissez la brosse rotative des deux extrémités et soulevez-la.
6. Retirez les ficelles, les cheveux et les autres débris de la brosse rotative et soyez particulièrement attentif aux extrémités de la brosse.
7. Retirez les ficelles, les cheveux et les autres débris des zones de la poulie du moteur et de la courroie d'entraînement.
8. Vérifiez si la courroie d'entraînement est usée, coupée ou endommagée.
9. Vérifiez si le passage d'air est obstrué. Retirez les débris de cette zone.



La brosse rotative pourrait provoquer le happement d'une frange d'un rideau à l'intérieur de l'aspirateur.

Soyez prudent et désactivez la brosse lorsque vous aspirez des rideaux avec des franges.

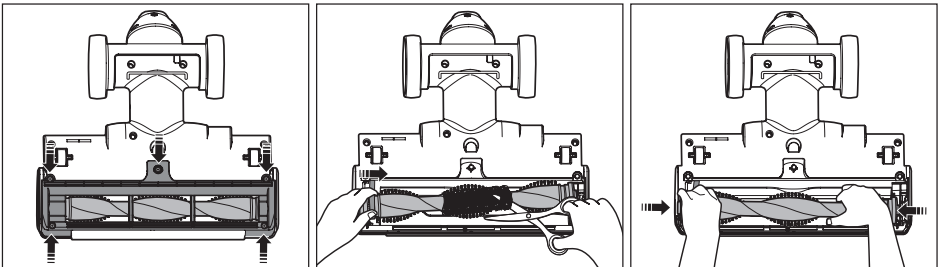

Brosse 2 positions (Série SC12F70H)

- Réglez la manette d'aspiration en fonction de la surface à nettoyer.



Moquette



Sol dur

- Retirez les saletés entièrement si l'orifice d'aspiration est bouché.

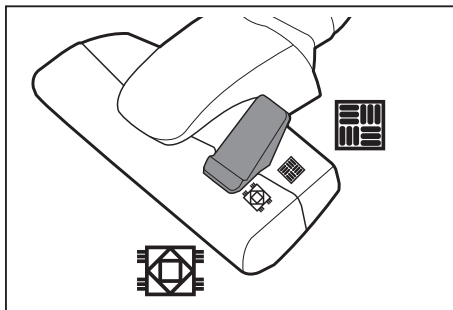

Brosse pour parquet (Série SC12F70P)

- Aspire la poussière d'une large zone d'une seule fois.
- Retirez les saletés entièrement de l'orifice d'aspiration s'il est bouché.

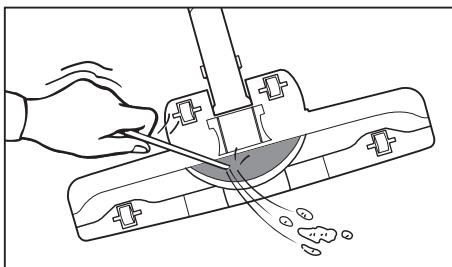
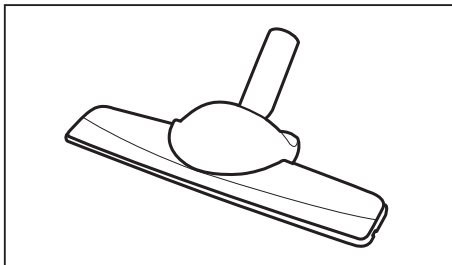

Brosse pour couverture (Série SC12F70P)

- Retirez les saletés entièrement si l'orifice d'aspiration est bouché.
- Placez le bouton de verrouillage sur (🔒) et retirez les saletés.
- Pour le remontage, alignez le capot à l'avant du corps principal et fermez. Une fois le capot fermé, assurez-vous que le bouton de verrouillage est bien sur la position (🔒).

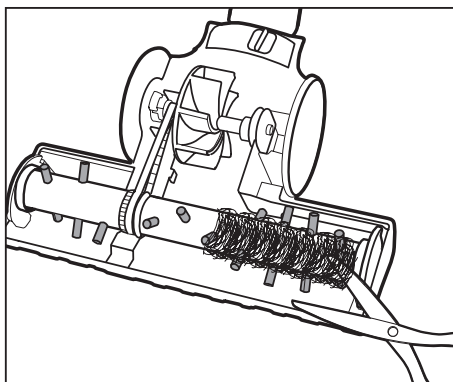
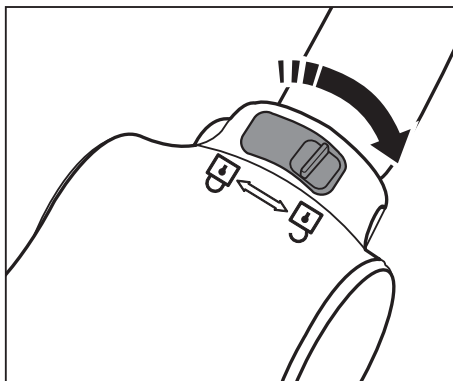

Utilisez cet accessoire uniquement pour le linge de lit. Prenez garde de ne pas endommager la brosse lorsque vous devez la déboucher.

Dépannage

PROBLÈME	SOLUTION
Le moteur ne démarre pas.	<ul style="list-style-type: none">• Vérifiez le câble, la fiche et la prise.• Laissez-le refroidir.
La puissance d'aspiration diminue progressivement.	<ul style="list-style-type: none">• Vérifiez que rien n'obstrue l'appareil et débouchez-le si nécessaire.• Nettoyez l'entrée obstruée.
Pendant l'utilisation, l'aspirateur s'arrête après s'être éteint et rallumé trois fois.	
Le cordon ne se rembobine pas entièrement.	<ul style="list-style-type: none">• Tirez environ 2 à 3 m de cordon et appuyez sur le bouton de rembobinage.
L'aspirateur n'aspire plus.	<ul style="list-style-type: none">• Vérifiez le flexible et remplacez-le si nécessaire.
Aspiration faible ou de moins en moins puissante.	<ul style="list-style-type: none">• Vérifiez le filtre et si nécessaire, nettoyez-le comme indiqué dans les instructions. Si les filtres sont usés, remplacez-les par des neufs.
Surchauffe de l'appareil.	<ul style="list-style-type: none">• Vérifiez les filtres et si nécessaire, nettoyez-les comme indiqué dans les instructions.
Décharge électrostatique	<ul style="list-style-type: none">• Diminuez la puissance d'aspiration.• Cela peut également se produire lorsque l'air de la pièce est très sec. Aérez la pièce pour que l'humidité de l'air devienne normale.
L'aspirateur émet un bruit étrange.	<ul style="list-style-type: none">• Afin de protéger le moteur de l'aspirateur, celui-ci tourne lentement lorsque vous allumez l'appareil. (Avant que le moteur ne se stabilise) cela provoque un bruit fort lors du démarrage et il ne s'agit donc pas d'un dysfonctionnement.



SerieSC12F70

Aspiradora manual del usuario

- * Antes de poner en funcionamiento la aspiradora, lea este manual detenidamente.
- * Para uso en interiores solamente.

Español

imagine the possibilities

Gracias por adquirir un producto Samsung.
Para recibir un servicio más completo,
registre su producto en
www.samsung.com/register

SAMSUNG

Contenido

SU ASPIRADORA

06

ANTES DE USAR LA ASPIRADORA

07

- 07 Montaje
- 08 Instalación del sensor de polvo (Serie SC12F70H)
- 08 Uso de los accesorios

FUNCIONAMIENTO DE LA ASPIRADORA

11

- 11 Cable de alimentación
- 11 Verificación del filtro
- 11 Encendido/Apagado
- 12 Control de potencia
- 13 Cepillo poderoso (Serie SC12F70P)
- 14 Sensor de polvo (Serie SC12F70H)

MANTENIMIENTO

15

- 15 Limpieza del depósito de polvo y la rejilla
- 18 Limpieza del filtro de salida
- 19 Cepillo poderoso (Serie SC12F70P)

SOLUCIÓN DE PROBLEMAS

23

Información sobre seguridad

INFORMACIÓN SOBRE SEGURIDAD



- Antes de poner en funcionamiento el aparato, lea detenidamente este manual y consérvelo para su referencia.



- Debido a que las siguientes instrucciones de funcionamiento corresponden a diversos modelos, es posible que las características de su aspiradora difieran ligeramente de las que se describen en este manual.

SÍMBOLOS DE PRECAUCIÓN Y ADVERTENCIA UTILIZADOS

	Indica que existe riesgo de muerte o lesiones graves.
	Indica que existe riesgo de lesiones personales o daños materiales.

OTROS SÍMBOLOS UTILIZADOS

	Representa algo que NO se debe hacer.
	Representa algo que se debe respetar.
	Indica que se debe desconectar el enchufe del tomacorriente.



Esta aspiradora es solo para uso doméstico.

No utilice esta aspiradora para limpiar escombros o residuos.

Limpie los filtros con regularidad para impedir que se acumule polvo fino en ellos.

No utilice esta aspiradora sin alguno de sus filtros.

Si no cumple estos requisitos podrían provocarse lesiones personales, daños a la aspiradora e invalidar la garantía.

INSTRUCCIONES DE SEGURIDAD IMPORTANTES

Cuando se utilizan aparatos eléctricos, siempre se deben seguir estas instrucciones básicas de seguridad:

LEA TODAS LAS INSTRUCCIONES ANTES DE USAR SU ASPIRADORA DE TRINEO

ADVERTENCIA – PARA REDUCIR EL RIESGO DE INCENDIO, DESCARGAS ELÉCTRICAS O LESIONES:

1. No deje el electrodoméstico enchufado. Desenchúfelo cuando no lo utilice y antes de realizar el mantenimiento.
2. No utilice la aspiradora en el exterior o sobre superficies húmedas.
3. No permita que se utilice la aspiradora como un juguete.
Preste especial atención cuando se utilice la aspiradora cerca de los niños.
4. Utilice la aspiradora sólo como se describe en el manual. Utilice sólo los accesorios recomendados por el fabricante.
5. No utilice la aspiradora si el cable o el enchufe están dañados.
Si el aparato no funciona como corresponde, se ha caído, se ha dañado, ha permanecido a la intemperie o se ha caído en el agua, llévelo a un centro de servicio.
6. No tire del cable ni lo utilice para trasladar la aspiradora, no lo utilice como asa, no lo aplaste con la puerta ni tire de él contra bordes o esquinas filosas.
No pase el electrodoméstico sobre el cable. Mantenga el cable alejado de superficies calientes.
7. No desenchufe la aspiradora tirando del cable.
Para desenchufar, tome el enchufe, no el cable.
8. No toque el enchufe o el electrodoméstico con las manos húmedas.
9. No inserte ningún objeto en las aberturas.
No utilice la aspiradora si hay aberturas obstruidas.
Manténgala libre de polvo, pelusa, cabello o cualquier cosa que reduzca el flujo de aire.
10. Mantenga el cabello, ropa suelta, sus dedos y todas las partes de su cuerpo lejos de las aberturas o partes móviles.
11. Apague todos los controles antes de desenchufar.
12. Tenga especial cuidado cuando limpie las escaleras.
13. No utilice la aspiradora para aspirar líquidos combustibles o inflamables, tales como gasolina, ni en áreas donde estas sustancias puedan estar presentes.
14. No aspire nada que esté encendido o humeando, como cigarrillos, fósforos o cenizas calientes.
15. No utilice la aspiradora sin la cubeta para polvo y/o filtros en su lugar.
16. No utilice la aspiradora en espacios cerrados donde se concentren vapores despedidos por pinturas al óleo, disolventes de pinturas, sustancias antipolillas, polvos inflamables y demás materiales tóxicos o explosivos.

17. No aspire objetos duros o cortantes, tales como vidrio, uñas, tornillos, monedas, etc.
18. La manguera contiene cables eléctricos. No la utilice si se encuentra dañada, cortada o pinchada.
Evite aspirar objetos cortantes.
19. Siempre apague este aparato antes de conectar o desconectar la manguera o la boquilla motorizada.
20. Desenchufe la aspiradora antes de conectar la boquilla motorizada.
21. Sujete el enchufe cuando enrolle el cable. No deje que el enchufe dé latigazos al enrollarlo.

GUARDE ESTAS INSTRUCCIONES

INSTRUCCIONES SOBRE EL ENCHUFE POLARIZADO

- Para reducir el riesgo de descarga eléctrica, este electrodoméstico cuenta con un enchufe polarizado (una punta es más ancha que la otra). Sólo hay una manera en que el enchufe se conectará con un tomacorriente polarizado. Dé vuelta el enchufe si no cabe totalmente en el tomacorriente. Si el enchufe aún no cabe, comuníquese con un electricista calificado para que instale el tomacorriente correcto. No modifique el enchufe de ninguna forma.

Advertencias de la Proposición 65 del Estado de California (solo EE.UU.):



Este producto contiene sustancias químicas que, según el Estado de California, provocan cáncer y toxicidad reproductiva.

Su aspiradora

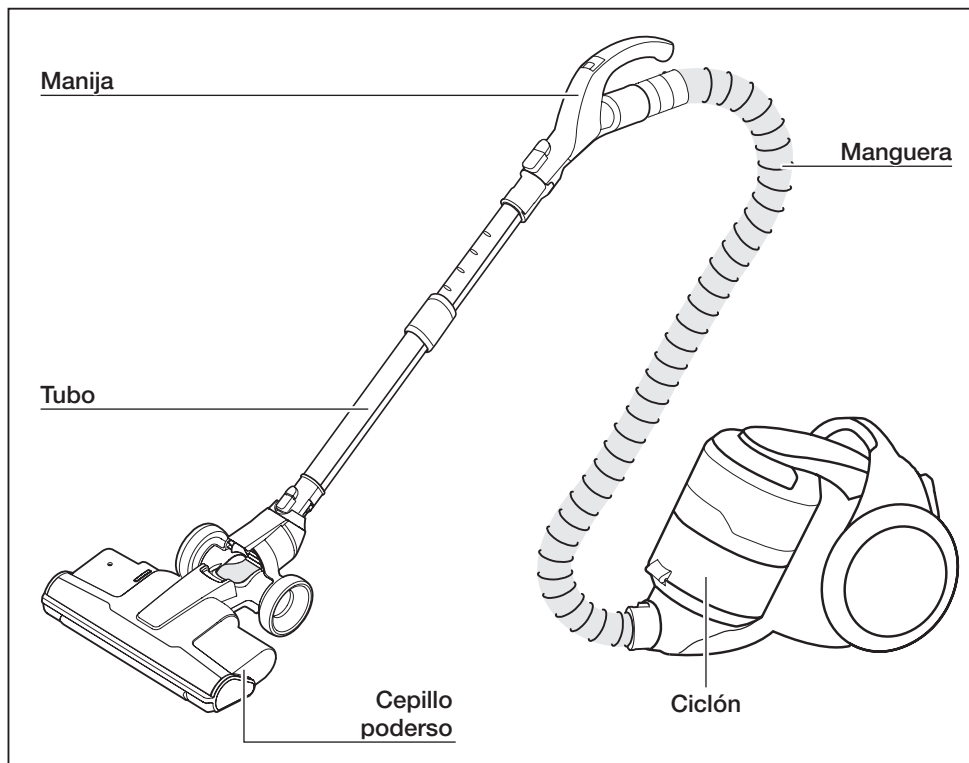

OPCIONALES (Serie SC12F70P)



Parqué



Cepillo para mantas



Cubierta de la batería



Accesorio 2 en 1



Tubo *



Manija *



Potencia turbo plus *



Cepillo de 2 posiciones*

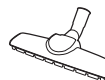

Cepillo maestro para parqué *



Sensor de polvo *

Serie SC12F70H

Antes de usar la aspiradora

MONTAJE

Conexión de la manguera

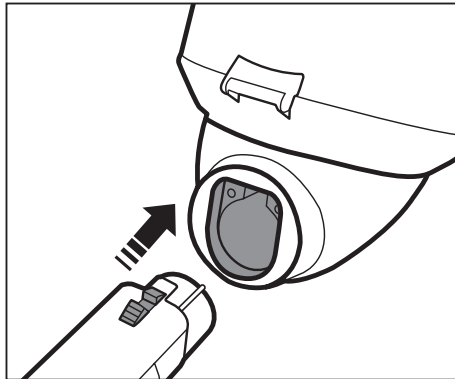

Conexión de la manija y el tubo

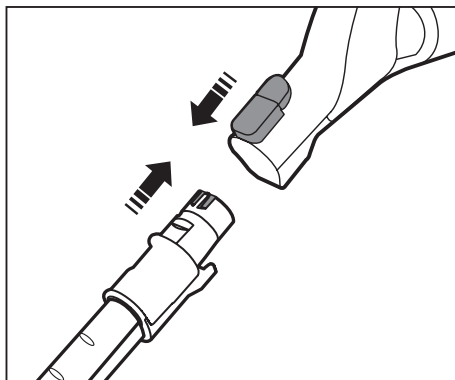

Conexión del cepillo

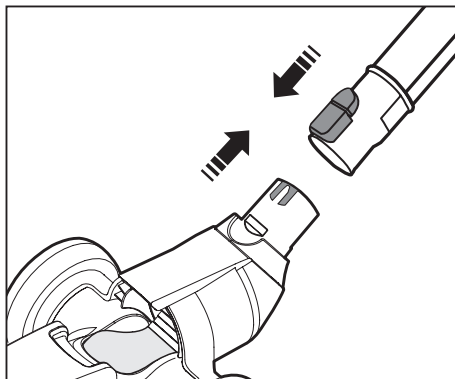

INSTALACIÓN DEL SENSOR DE POLVO (Serie SC12F70H)

Montar el sensor de polvo

entre el cepillo y el tubo
entre el tubo y la manguera

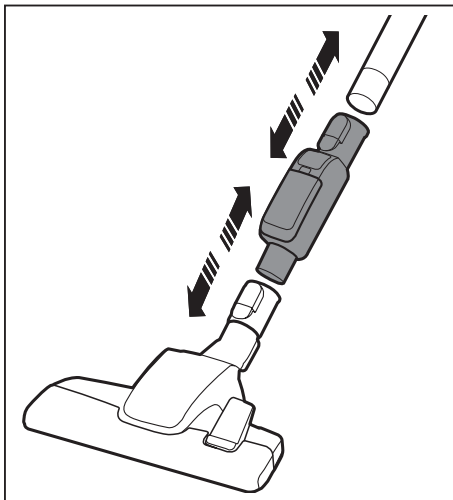

USO DE LOS ACCESORIOS

Accesorios (Serie SC12F70P)

Instalar el accesorio en la manija.



Cepillo para polvo



Boquilla para rincones

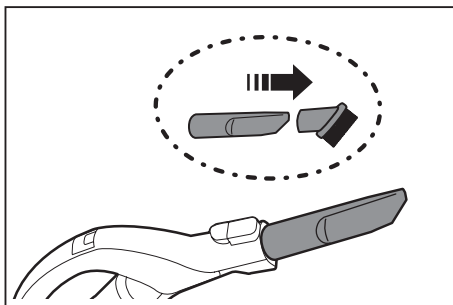

Cepillo para polvo - Para limpiar molduras, artículos tallados, etc.

Boquilla para rincones - Para limpiar pliegues, grietas y esquinas.

Accesorio de combinación (Serie SC12F70H)

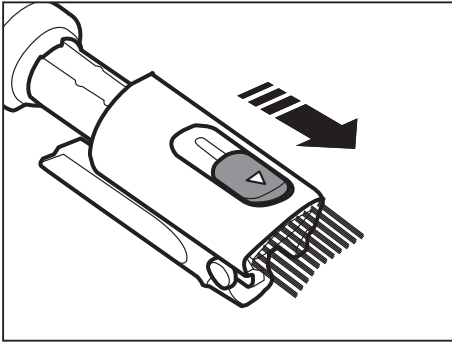
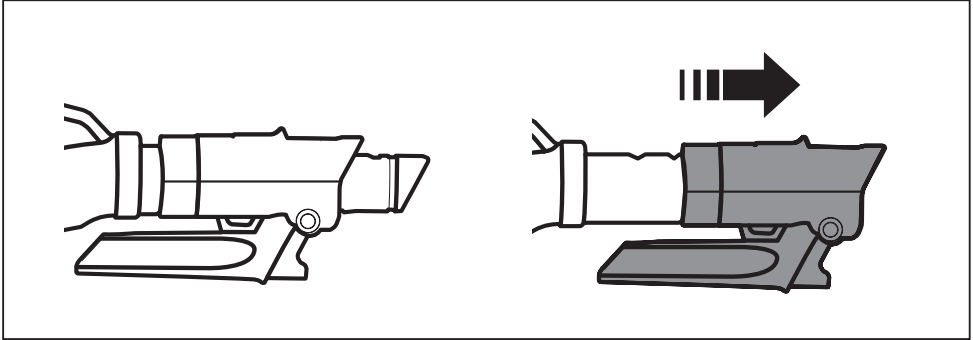

Cepillo para polvo

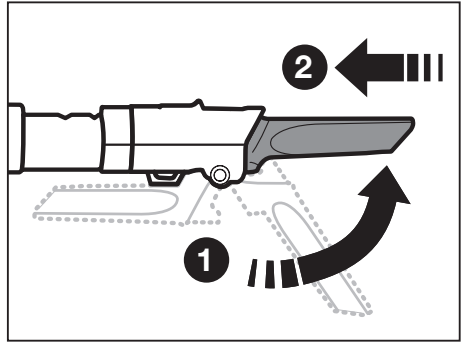

Boquilla para rincones

Tubo

Ajuste la longitud del tubo deslizando el botón del control de longitud ubicado en el centro del tubo telescópico.

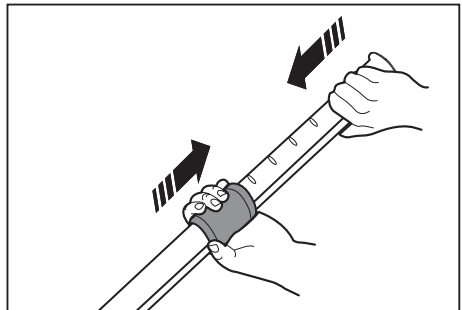

Al guardar la aspiradora, deje la boquilla para pisos como se muestra
(SC12F70H Serie)

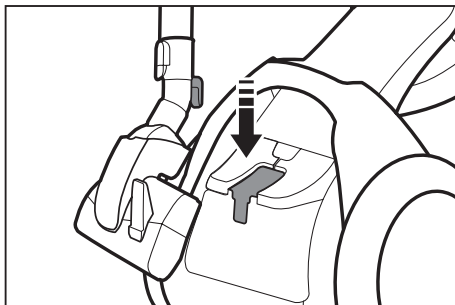

PRECAUCIÓN

No mueva la máquina con la boquilla para pisos instalada.

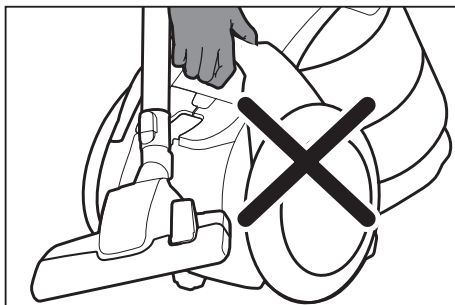

Para el almacenamiento, en posición vertical de la tubería en el suelo
(SC12F70P Serie)

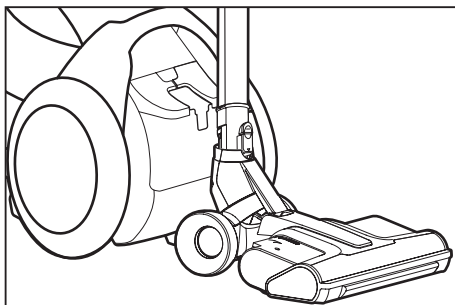

Funcionamiento de la aspiradora

CABLE DE ALIMENTACIÓN

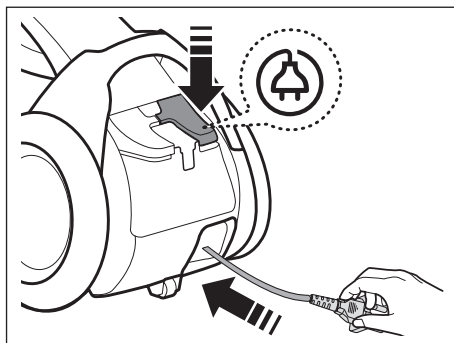
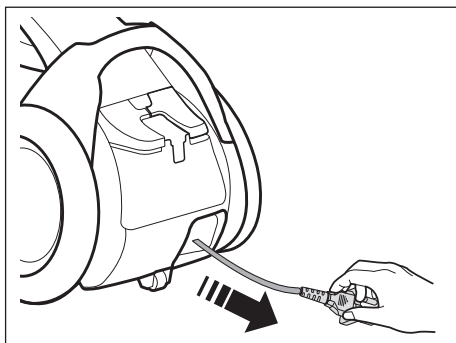

PRECAUCIÓN

Cuando desenchufe el aparato del tomacorriente, sujete por el enchufe, no por el cable.

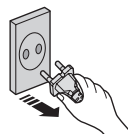

VERIFICACIÓN DEL FILTRO

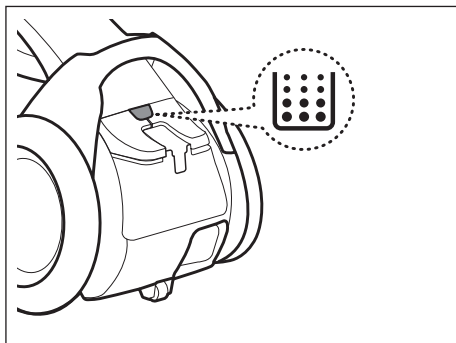

La luz del filtro se ilumina cuando la caja para polvo requiere verificación o vaciado.

ENCENDIDO/APAGADO

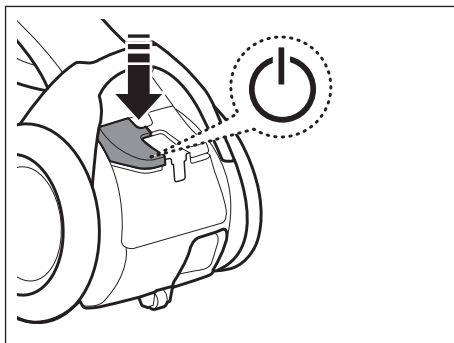

CONTROL DE POTENCIA

Manguera (controlada por señales de radio frecuencia)



Encendido/Apagado

Serie SC12F70P



Seleccionar una potencia más baja / más alta



Encendido/Apagado del Cepillo poderso

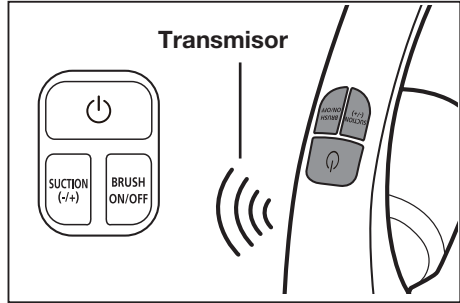

Serie SC12F70H



Seleccionar una potencia más baja / más alta



Seleccionar un modo silencioso

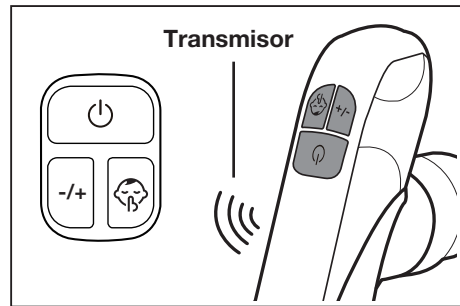

• No cubra el transmisor de la manija cuando utilice un botón del control de la manija.



PRECAUCIÓN

1. Nunca desarme las pilas ni las recargue.
2. Nunca caliente las pilas ni las tire en el fuego.
3. No invierta los polos (+) y (-).
4. Deseche las pilas de la manera correspondiente.

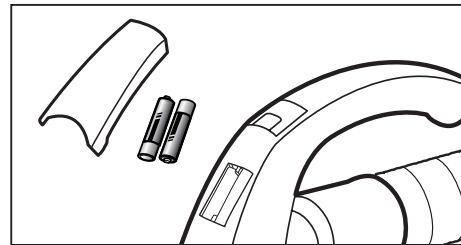

TIPO DE PILA: Tamaño AAA

AVISO DE LA FCC / FCC ID: A3LROH20S

Este aparato cumple con la sección 15 de las Normas de la FCC. El funcionamiento se encuentra sujeto a las siguientes dos condiciones:

1. Este aparato no puede causar interferencia dañina, y
2. Este aparato debe aceptar la recepción de cualquier interferencia, incluidas aquellas que puedan causar un funcionamiento indeseado.

CEPILLO PODERSO (Serie SC12F70P)

Cómo aspirar con el cepillo poderso

1. Colocación del cepillo poderso

- La manguera debe conectarse al trineo y el cepillo poderso debe conectarse a la manguera y al tubo de extensión.

2. Aspiración

- Para obtener mejores resultados, desplace el cepillo poderso lentamente haciendo recorridos cortos y superpuestos.
- En áreas muy sucias, repita los recorridos en distintas direcciones.

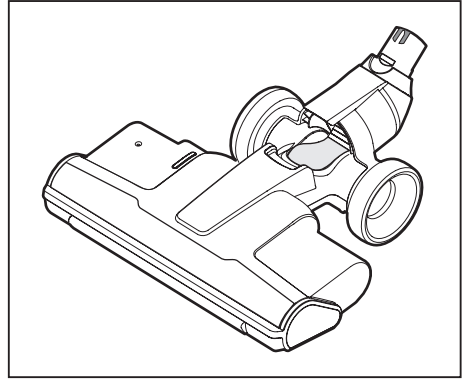

No invierta el cepillo poderso mientras está en funcionamiento.

3. Verificación del rendimiento del cepillo poderso

Puede verificar si el cepillo poderso funciona con normalidad levantando levemente el tubo de extensión para ver la parte posterior del cepillo.

El cepillo poderso no funcionará si se encuentra atascado o si la unidad está apagada. Si el cepillo poderso se encuentra atascado, desenchufe el cable de alimentación del tomacorriente.

Dé vuelta el cepillo poderso y quite el objeto atascado.

Vuelva a colocar el cepillo poderso en la posición adecuada y siga aspirando.

Protector contra sobrecarga

El protector contra sobrecarga apaga el motor del cepillo si el cepillo para piso se obstruye. El cepillo para piso se detendrá, pero el motor de succión seguirá en funcionamiento. Para restablecer el protector contra sobrecarga, apague la aspiradora y desenchúfela. Elimine la obstrucción del cepillo para piso. Utilice la punta de un bolígrafo para presionar el interruptor para restablecer el protector. Encienda la aspiradora y siga limpiando.

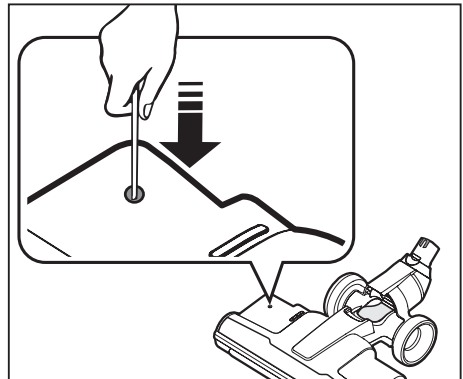

SENSOR DE POLVO (Serie SC12F70H)

Operaciones del sensor de polvo

- Indica la cantidad de polvo que se recoge y pasa por el sensor, lo que ayuda al usuario a limpiar de manera más eficiente.
- El sensor de polvo se activa automáticamente al poner en funcionamiento la aspiradora y se apaga al detenerla.



Verde : la cantidad de polvo que pasa por el sensor es pequeña.

Rojo : la cantidad de polvo que pasa por el sensor es grande.

Si la luz roja no se enciende al limpiar un área con mucho polvo

- Limpie los sensores (2) con un paño seco.
- Tenga cuidado cuando utilice la aspiradora porque el sensor de polvo puede funcionar mal o romperse debido a un impacto.

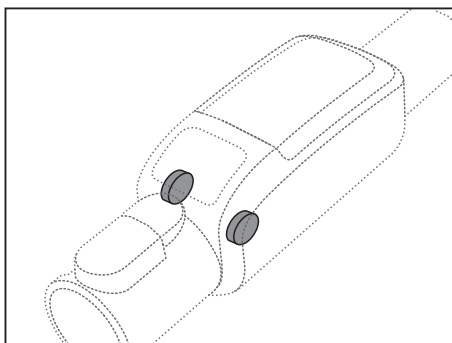
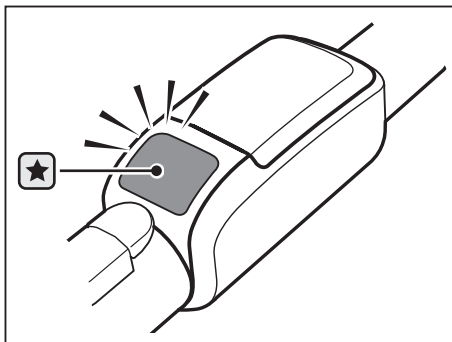

Instalación de las pilas

Si el sensor del polvo no funciona, cambie las pilas.

TIPO DE PILA: tamaño AAA 

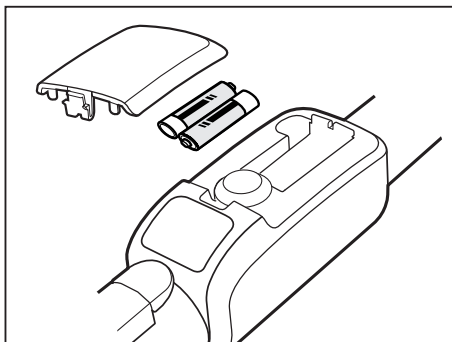

Mantenimiento

LIMPIEZA DEL DEPÓSITO DE POLVO Y LA REJILLA

Vacíe el depósito de polvo si alcanza el nivel 'MÁX' o si se enciende la luz de verificación del filtro ().

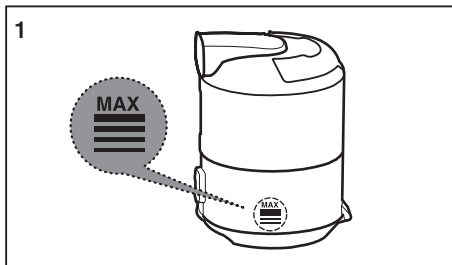

Extraiga el depósito de polvo levantando la manija.

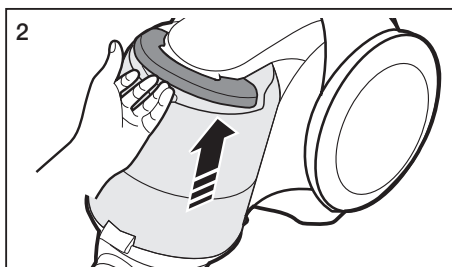

Empuje el botón hacia un lado

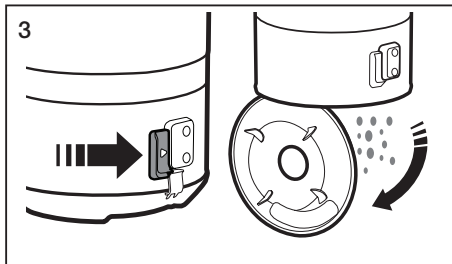

Gire la rejilla y extráigala.

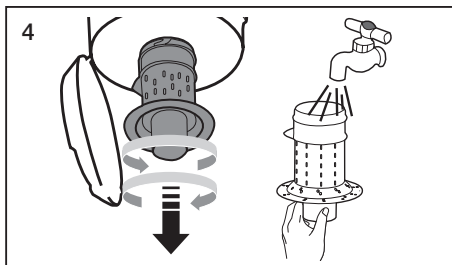

Presione el botón.
Separe el depósito de polvo del cuerpo de la aspiradora.

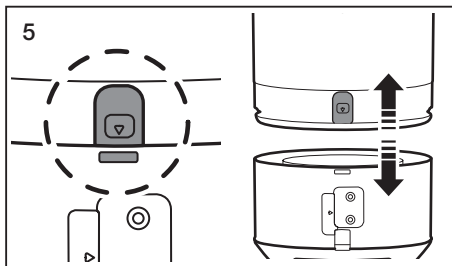

Limpie el depósito de polvo y el cuerpo de la aspiradora con agua.

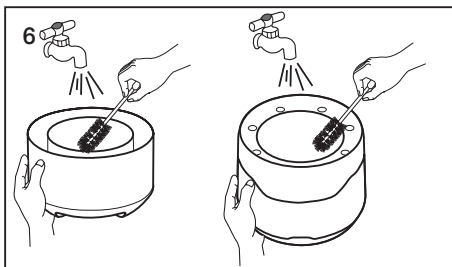

Deje el depósito de polvo y el cuerpo de la aspiradora a la sombra hasta que se sequen completamente.

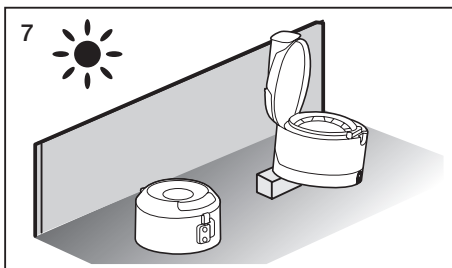

Instale la rejilla y gírela en el sentido de las agujas del reloj.

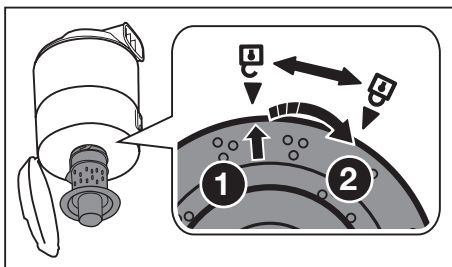

LIMPIEZA DEL FILTRO DE POLVO

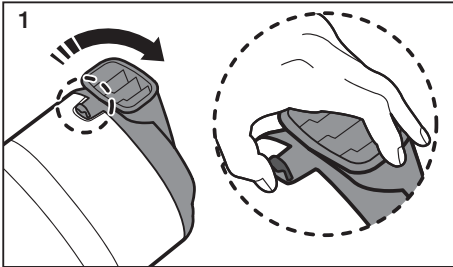

1 Tire de la tapa del depósito de polvo para abrirla.

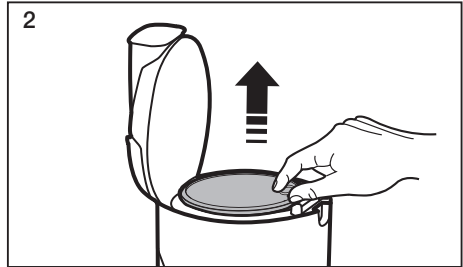

2 Extraiga el filtro del depósito de polvo.

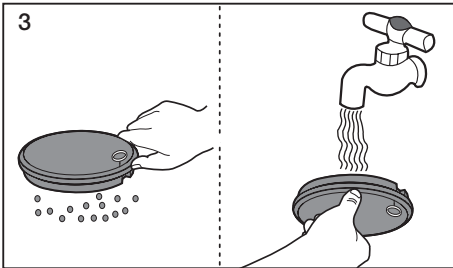

3 Sacuda el filtro para eliminar el polvo y, luego, lávelo.

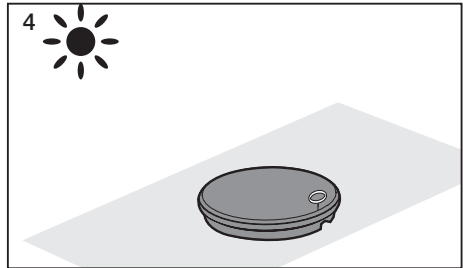

4 Deje secar el filtro durante más de 12 horas.

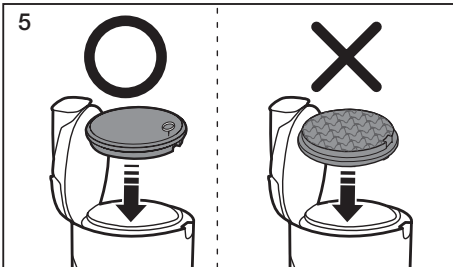

5 Ponga el filtro en el depósito de polvo.



Asegúrese de que el filtro esté completamente seco antes de volver a colocarlo en la aspiradora. Espere 12 horas para que se seque.

No utilice un filtro húmedo.

Si el filtro de polvo está dañado o deformado, reemplácelo.

La tapa del depósito de polvo no se cerrará si el filtro no está correctamente instalado.



LIMPIEZA DEL FILTRO DE SALIDA

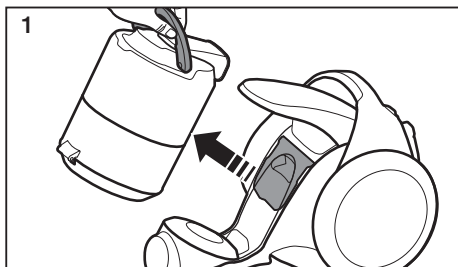

1
Extraiga el depósito de polvo levantando la manija.

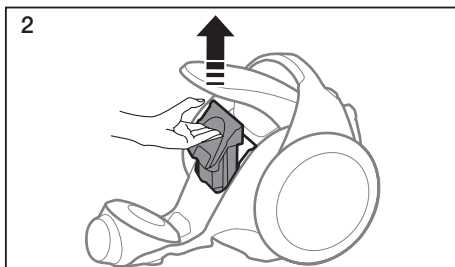

2
Extraiga el filtro HEPA.

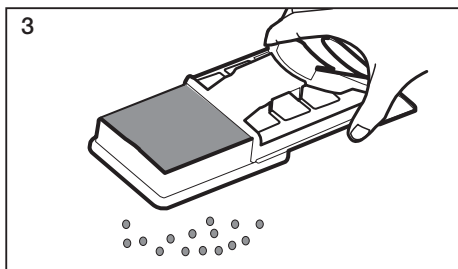

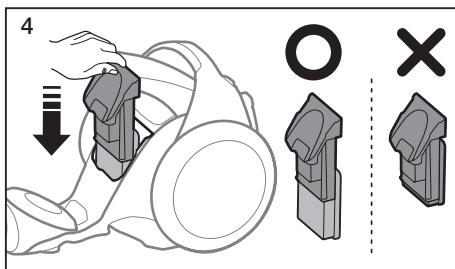

3
Sacuda el filtro HEPA para limpiarlo.

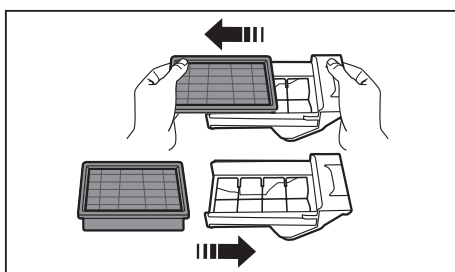

4
Instale el filtro y el soporte en el cuerpo principal.

-  Se puede tirar del filtro para reemplazarlo y separarlo del soporte.



-  Si la potencia de succión disminuye considerablemente de forma continua o la aspiradora se recalienta de manera anormal, limpie el filtro de salida.
Nota: Los filtros HEPA no son lavables.
Si la limpieza del filtro no resuelve el problema, reemplácelo.
- Se recomienda cambiar el filtro HEPA una vez cada 6 meses.

CEPILLO PODERSO (Serie SC12F70P)

Verificación del cepillo giratorio para piso y de la correa de accionamiento

Verifique regularmente que el cepillo giratorio para piso y la correa de accionamiento de la aspiradora no estén desgastados o dañados. También debe quitar los hilos, los cabellos y las fibras de la alfombra del cepillo y de los extremos del cepillo. Estos pueden enrollarse en el cepillo y dificultar la eficacia para limpiar su alfombra. Extraiga también cualquier residuo que pueda haberse acumulado debajo de la tapa del cepillo.

1. Desenchufe la aspiradora del tomacorriente.
2. Coloque la manija en una posición baja y dé vuelta la aspiradora de manera tal que la parte inferior quede hacia arriba.
3. Retire los cinco tornillos (señalados con las flechas en la ilustración) con un destornillador.
4. Extraiga la tapa del cepillo del cepillo para piso.
5. Tome el cepillo giratorio para piso de los dos extremos y levántelo.
6. Quite los hilos, los cabellos y otros residuos del cepillo giratorio para piso prestando especial atención a los extremos del cepillo.
7. Quite los hilos, los cabellos y otros residuos de las áreas donde se encuentran la polea del motor y la correa de accionamiento.
8. Verifique cuidadosamente que la correa de accionamiento no esté desgastada, ni presente cortes o torceduras.
9. Verifique que no haya obstrucciones en la salida de aire. Retire los residuos de esta área.



El cepillo giratorio para piso puede hacer que los flecos de alfombras se enreden dentro de la aspiradora.

Sea cauteloso y apague el cepillo para piso al aspirar alfombras con flecos.

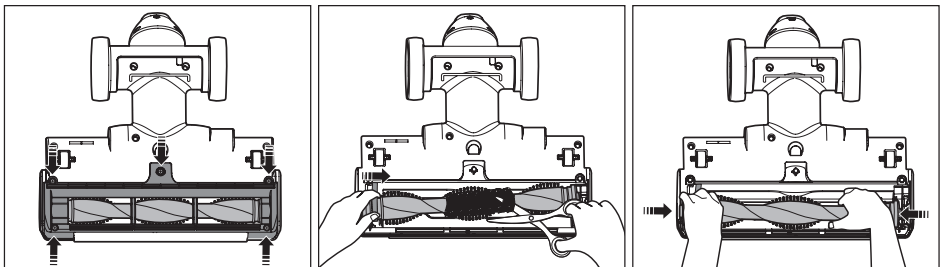

Cepillo de 2 posiciones (Serie SC12F70H)

- Ajuste la palanca de entrada según la superficie del piso.



Alfombra



Piso

- Extraiga completamente los materiales de desperdicio si la entrada está bloqueada.

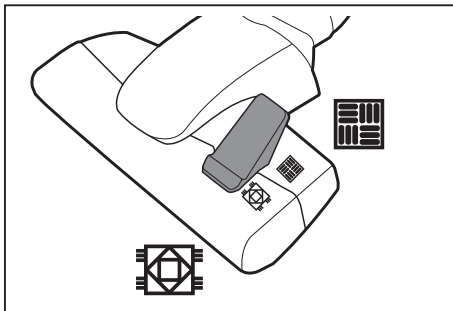

Cepillo para parqué (Serie SC12F70P)

- Aspira el polvo de una vez en áreas amplias.
- Extraiga completamente los materiales de desperdicio de la entrada, si esta se encuentra bloqueada.

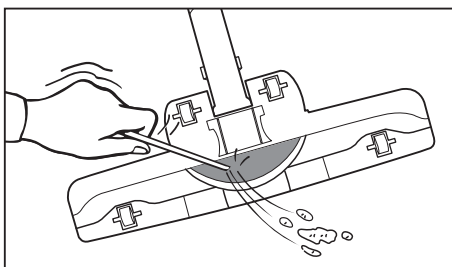
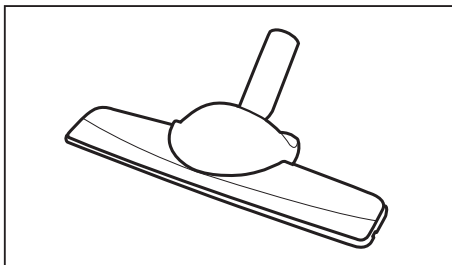

Cepillo para mantas (Serie SC12F70P)

- Extraiga completamente los materiales de desperdicio cuando la entrada esté bloqueada.
- Gire el botón de bloqueo a la posición (🔒) y extráigalo.
- Para rearmar, alinee la cubierta con el frontal del cuerpo principal y ciérrela. Luego de cerrar la cubierta, asegúrese de que el botón de bloqueo esté en la posición (🔒).

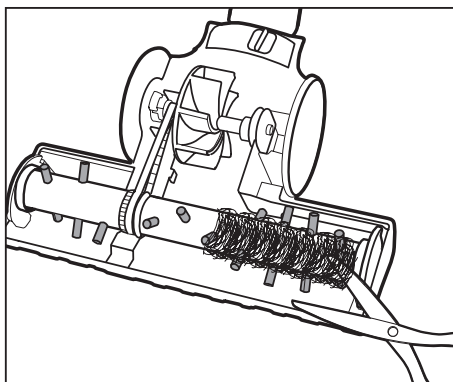
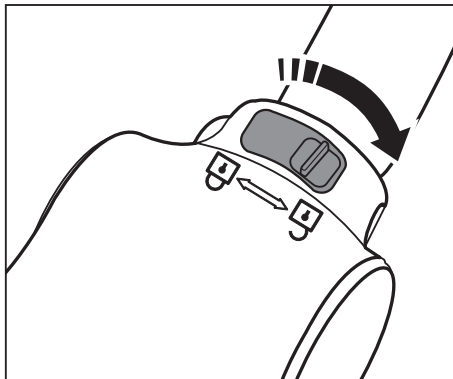

Use solo para la ropa de cama. Tenga cuidado de no dañar el cepillo al desobstruirlo.

Solución de problemas

PROBLEMA	SOLUCIÓN
El motor no arranca.	<ul style="list-style-type: none">• Verifique el cable, el enchufe y el tomacorriente.• Deje enfriar.
La potencia de succión disminuye gradualmente.	
En funcionamiento, la aspiradora se detiene después de repetidas ejecuciones y se detiene tres veces.	<ul style="list-style-type: none">• Verifique si hay obstrucciones y elimínelas.• Quite las obstrucciones de la entrada.
El cable no se enrolla completamente.	<ul style="list-style-type: none">• Tire del cable unos 2 a 3 metros y, luego, presione el botón para enrollar el cable.
La aspiradora no aspira polvo.	<ul style="list-style-type: none">• Limpie la manguera y reemplácela si es necesario.
Potencia de succión baja o decreciente.	<ul style="list-style-type: none">• Verifique el filtro y, si es necesario, límpielo como se indica en las instrucciones. Si los filtros están inutilizables, reemplácelos por otros nuevos.
Recalentamiento del cuerpo de la aspiradora.	<ul style="list-style-type: none">• Verifique los filtros y, si es necesario, límpielos como se indica en las instrucciones.
Descarga de electricidad estática.	<ul style="list-style-type: none">• Baje la potencia de succión.• Esto también puede suceder si el aire de la habitación es muy seco. Ventile la habitación hasta que la humedad sea normal.
La aspiradora hace un ruido extraño.	<ul style="list-style-type: none">• Para proteger el motor de la aspiradora, este gira lentamente al encenderla. (Antes de que el motor se estabilice,) esto causa el fuerte ruido al inicio y no es una falla de la máquina.



If you have any questions or comments relating to Samsung products, please contact the SAMSUNG customer care center.

Country	Customer Care Center ☎	Web Site
U.S	1-800-SAMSUNG	www.samsung.com/us
CANADA	1-800-SAMSUNG (726-7864)	www.samsung.com



DJ68-00701R-03