



## Special edition Evolution 250 food waste disposer

This special edition version of our quietest and most powerful food waste disposer stands out from the crowd. It features black trim, a new style trim shell and a premium stainless steel sink stopper with cover. It is supplied with built-in air switches in black, chrome and brushed steel and is supported by an 8 year parts and service guarantee.

### Features

- Built-in air switch in black, chrome and brushed steel
- 8 year guarantee
- Deluxe stopper cover
- New style trim shell
- Evolution Ultra-quiet technology
- Evolution 3-stage grind technology
- Auto-reverse grinding action
- High-torque Dura-Drive™ induction motor
- Stainless steel grind elements and grind chamber
- Overload protection
- Quick Lock® mounting assembly for faster, easier installation



**PRODUCT  
SPEC SHEET**

Showroom  
collection:  
Evolution 250  
food waste

Specifications (mm)

Dimensions (mm)

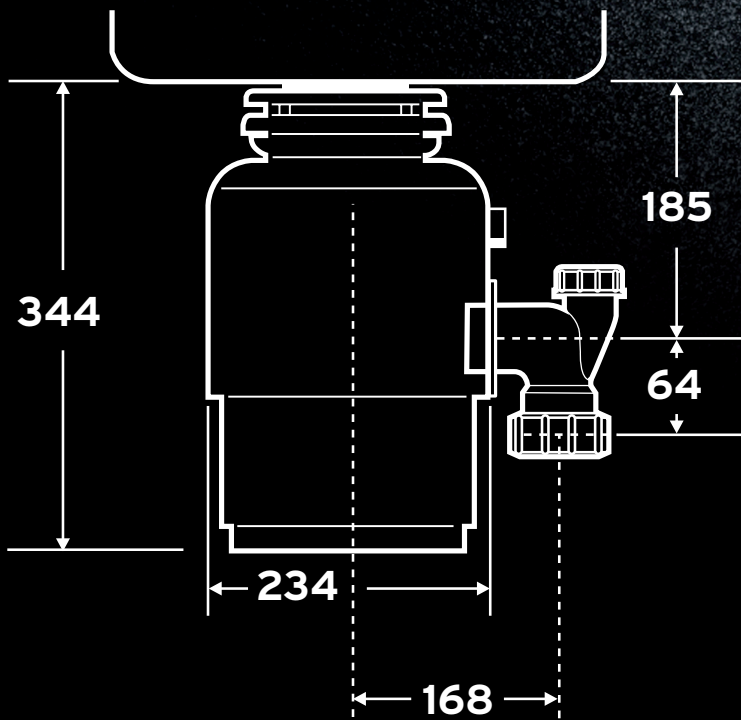

Type of feed	Continuous
On/Off Control	Wall switch or built-in air switch
Motor	Single phase
Reversing	Auto-reverse grind system
Time Rating	Intermittent
Lubrication	Permanently lubricated upper & lower bearings
Shipping Weight (Approx.)	11.6kg
Unit Finish	Stainless steel light Gray TEN-1706
Overall Height	344mm
Grind Technology	3-stage grind technology Power booster circuit with microprocessor technology included
Sound Technology	Anti-vibration mounting and tailpipe Quiet sink baffle multi layer sound insulation Stainless steel strainer basket & plug
Grind Chamber Capacity	1180ml
Motor Protection	Manual reset overload
Average Water Usage	Approximately 4.0L per person per day
Average Electrical Usage	3-4KWH per annum
Drain Connection	1-1/2" (3.81cm) anti vibration (hose clamp)
Dishwasher Drain Connection	Yes

Compatible with Cover control



For those who prefer the on/off switch built right into the disposer cover, InSinkErator offers the cover control accessory. It's just right for efficient batch feed operation.

(Not available in all markets.)

Volts/Hz	HP	RPM	Average Load
120V, 60Hz	1.0	1725	10.2 A
220-240V, 50Hz	.75	1425	380 W
220-240V, 60Hz	.75	1725	370 W



InSinkErator  
Suite 10, Building 6  
Hatters Lane  
Croxley Green Business Park  
Watford, Herts WD18 8YH  
United Kingdom

Sales tel: (0) 1 923 297 880  
Service tel: (0) 800 389 3715  
www.insinkerator.co.uk

InSinkErator  
Emerson Electric Co.  
4700 21st Street  
Racine, WI 53406-5093 USA

Sales/Service tel: 262-554-5432  
www.insinkerator.com/worldmap.

