



#### Color Variants

**RY492304**  
With fresh cooling close to 0 °C  
Fully integrated

#### Included accessories

1 x egg box with lid.  
1 x ice cube scoop.

#### Optional accessories

**RA430100**  
Storage container with transparent lid, anthracite.  
**RA450000**  
Mechanical particle filter.  
**RA450010**  
Activated charcoal filter for water filter system including saturation indicator.

#### Installation Accessories

**RA421912**  
Stainless steel door panels with handles  
**RA423340**  
Side trims, 2 pieces, for RY and RB.  
**RA425110**  
Handle bar, stainless steel, long  
**RA425910**  
Handle bar, stainless steel, short  
**RA428912**  
Stainless steel door panels, handleless  
**RA460000**  
Accessory for side-by-side installation. Required if appliances are installed handle to handle. Not required if appliances are installed more than 160 mm apart from each other. Included in delivery for RF and RW.  
**RA460013**  
Additional side heating element 230 V. Required if appliances are installed handle to hinge or hinge to hinge. Not required if appliances are installed more than 160 mm apart from each other.  
**RA460030**  
Connecting element for vertically split fronts (for fridge-freezer combination).  
**RA464910**  
Ventilation grille stainless steel

#### RY492304

Vario fridge-freezer combination 400 series

With fresh cooling close to 0 °C

Fully integrated

Niche width 91.4 cm, Niche height 213.4 cm

Cooling section with two doors and one fully extendable freezing drawer

Stainless steel interior with solid anthracite aluminium elements  
Warm white and glare-free LED light spots

Opening assist for door with two options:

1. Push-to-open function for integration into handleless furniture front

2. Pull-to-open function to facilitate opening the door using a handle  
Flat stainless steel inner doors  
Almost invisible rail system for shelves and door racks for flexible positioning

Solid anthracite aluminium door racks

1 fresh cooling drawer close to 0 °C with manually adjustable temperature and 1 fresh cooling drawer with manually adjustable humidity

Integrated ice maker with fixed inlet water connection

1 asymmetrically split glass shelf, height adjustable

Fully extendable freezer drawer with practical divider in anthracite  
TFT touch display  
Net volume 518 litres

#### Handling

TFT touch display operation.  
Clear text display.

#### Technical Features

Dynamic cold air distribution.  
Automatic defrosting with defrost water evaporation.

Cushioned door closing system.

Activated charcoal air filter.

Rest mode certified by Star-K.

When rest mode is active, the appliance can only be opened using a handle.

Open-door and malfunction alarm.

Home network integration for digital services (Home Connect) wireless via WiFi.

The use of the Home Connect functionality depends on the Home Connect services, which are not available in every country. For further information please check: [home-connect.com](http://home-connect.com).

#### Cooling

No-Frost technology with fast cooling.  
Temperature adjustable from +2 °C to +8 °C.

3 safety glass shelves, white glass, 2 of which are individually adjustable in height.

1 asymmetrically split safety glass shelf, with manual height adjustment.

4 brilliant LED light spots with warm white, glare-free light within cooling area and drawers.

Flat door rail system with fully flexible positioning of door racks.

6 height-adjustable door racks, 2 of which are extra deep.  
Net volume 344 litres.

#### Fresh cooling close to 0 °C

1 fully extendable fresh cooling drawer close to 0 °C with transparent front, illuminated.

Temperature can be adjusted manually.  
Ideal for meat, fish and poultry.  
Net volume 34 litres.

#### Fresh cooling

1 fully extendable fresh cooling drawer with transparent front, illuminated.  
Humidity can be adjusted manually.

#### Characteristics

Built-in / Free-standing

Built-in

Number of compressors

2

Number of independent cooling systems

2

Width of the product (mm)

908

Height (mm)

2125

Depth of the product

608

Net weight (kg)

223.601

Required niche size for installation (HxWxD)

2134.0 x 914.0 x 610

Door panel options

Not possible

Door hinge

left and right

Number of Adjustable Shelves in fridge compartment

2

Shelves for Bottles

No

Frost free system

Full

Interior ventilator

Yes

Reversible Door Hinge

No

Length electrical supply cord (cm)

300

Noise level (dB)

42

Multi-Flow Air Tower

Yes

Fast cooling switch

Yes

Fast freezing switch

Yes

Carbon Air Filter

No

Temperature Controlled Drawer

No

Humidity Control Drawer

Yes

Number of Door Bins - Refrigerator

6

Door bin adjustability - Refrigerator

No

Tilt-out door bins in fridge

Number of Gallon storage

2

No. of shelves in fridge

3

Number of shelves - Freezer

Shelf Adjustability - Freezer

No

Capacity of Water Tank [l]

#### Consumption and connection features

Connection Rating (W)

300

Current (A)

10

Voltage (V)

220-240

Frequency (Hz)

50-60

Energy consumption (kWh)

Freezing capacity (kg)

Storage Period in Event of Power Failure (h)

17

Approval certificates

CE, VDE

Universal Product Code

Color / Material body

Colour.Material door

Door panel options

Not possible

Noise level (dB)

42

Total annual energy consumption (kWh)

Energy Star Qualified

No

Length of electrical supply cord (in)

Ideal for fruit and vegetables.

#### Freezing

No-frost technology with fast freezing at -30 °C.

Temperature adjustable from -16 °C to -24 °C.

4-star freezer compartment.

Freezing capacity 16 kg/24 h.

Storage time after a malfunction 17 h.

2 fully extendable drawers.

Interior lighting with 2 LED light spots, warm white light.

Net volume 140 litres.

#### Ice maker

Integrated in the freezer compartment, with fixed inlet water connection.

Particle filter for water inlet, integrated in ventilation grille area.

Can be switched off.

Ice cube production approx. 1.6 kg/24 h.

Removable ice storage container with approx. 3 kg capacity.

#### Consumption data

Energy efficiency class A++ at a range of energy efficiency classes from A++ to D.

Energy consumption 346 kWh/year.

Noise level 42 dB (re 1 pW).

#### Planning notes

Flat hinge.

Door opening angle of 115°, fixable at 90°.

Max. door panel weight:

Each door 67 kg.

Drawer 10 kg.

Shut-off valve for water connection must be planned next to the appliance and always be accessible.

If the water pressure exceeds 0.8 MPa (8 bar), connect pressure relief valve between water tap and hose set.

#### Connection

Total connected load 0.300 kW.

Connecting cable 3.0 m, pluggable.

Water inlet.

Supply hose 2.0 m with 3/4" connection.

Water pressure 2 to 8 bar.

RY492304

Vario fridge-freezer combination 400 series

With fresh cooling close to 0 °C  
Fully integrated

Niche width 91.4 cm, Niche height 213.4 cm

Cooling section with two doors and one fully extendable freezing drawer

2019-03-21  
Page 2

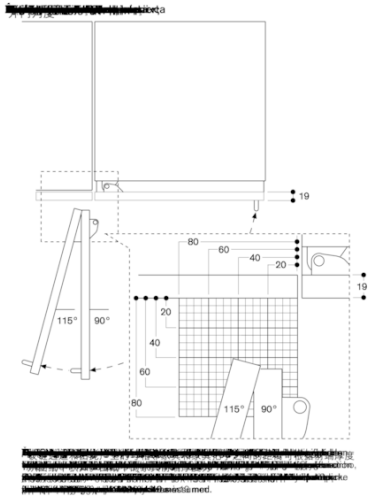

Wall clearance RB 492/RV 492

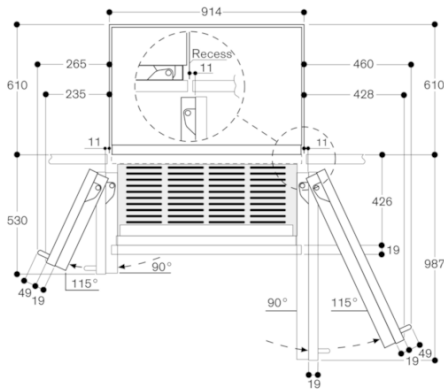

In the drawing, a unit front thickness of 19 mm and a Gaggenau unit handle of 49 mm were taken as a basis.

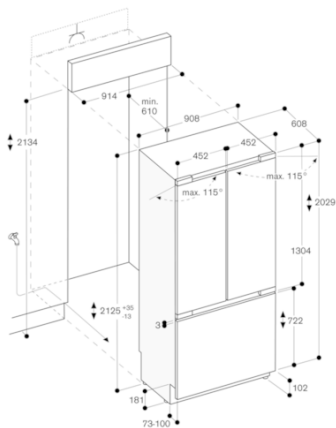

The maximum door panel dimensions are based on a clearance of 3 mm.

Base detail

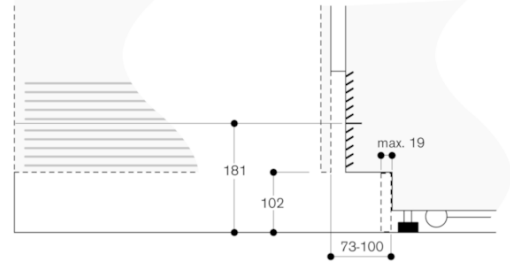

Based on the standard appliance height, the height of the plinth is 102 mm. Maximum plinth thickness 19 mm.

