



VG295150F
Gas cooktop 200 series
Width 90 cm
Liquid gas 28 - 37 mbar
Wok burner with up to 5.8 KW

Control panel for comfortable and secure operation
Mechanical power level regulation for 9 power levels, with exact setting and reproduction of flame size
Multi-ring burner of solid, heat-resistant brass as used in professional kitchen
Solid smooth-surface cast iron pan supports
Up to 17.8 kW on 5 burners

Cooking zones

1 multi-ring wok burner (300 W – 5800 W), suitable for pots up to max. ø 32 cm.
2 two-ring high output burners (170 W – 4000 W), suitable for pots up to max. ø 28 cm.
2 two-ring standard burners (170 W – 2000 W), suitable for pots up to max. ø 24 cm.

Handling

Control knobs with illuminated ring.
Integrated control panel.
One-handed operation.
Electric ignition.

Features

Three-part cast iron pan support with flat, continuous pot surface.
Brass burner rings.

Safety

Thermoelectric safety pilot.
Residual heat indication.
Operation indicator.

Planning notes

Special nozzles for natural gas 20 mbar can be ordered as spare parts.
No intermediate shelf required.
Appliance can be snapped into the worktop from above.
Rear panel and wall trims must be heat-resistant and consist of a non-flammable material.
Installation in a 90 cm wide lower cabinet is required.
A minimum lateral clearance of at least 300 mm from adjacent heat-sensitive furniture or contact surfaces must be observed or thermal insulation fitted.
With a total connected load of more than 11 kW local regulations concerning room ventilation, room size and combination of extraction or recirculation hoods must be observed.
Minimum clearance between gas cooktop(s) with more than 11 kW and ventilation hood 70 cm.
Appliance weight: approx. 29 kg.

Connection

Total connected load gas 17.8 KW.
Total connected load electric 10 W.
Connecting cable 1.5 m with plug.

Characteristics

Product name/family
gas hob w integrated controls
Built-in / Free-standing
Built-in
Energy input
Gas
Total number of positions that can be used at the same time
5
Required niche size for installation (HxWxD)
106 x 885 x 492
Width of the appliance
914
Dimensions
132 x 914 x 510
Dimensions of the packed product (HxWxD)
290 x 700 x 1020
Net weight
29.5
Gross weight
31.8
Residual heat indicator
Separate
Location of control panel
Hob front
Basic surface material
brushed stainless steel
Color of surface
Stainless steel
Color of frame
Stainless steel
Approval certificates
VDE
Length electrical supply cord
150
Connection rating
10
Gas connection rating
17800
Fuse protection
10
Voltage
220-240
Frequency
50-60

Consumption and connection features

2022-04-27
Page 1

Color Variants

VG295150F
Width 90 cm
Liquid gas 28 - 37 mbar

Included accessories

1 x WOK attachment ring.

Optional accessories

WP400001
Wok pan made of multiple-layer material

VG295150F
Gas cooktop 200 series
Width 90 cm
Liquid gas 28 - 37 mbar
Wok burner with up to 5.8 KW
2022-04-27
Page 2

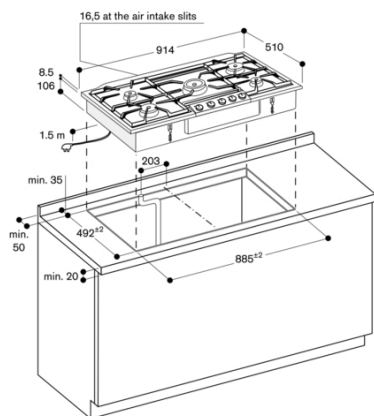

Minimum distance from the appliance cut-out to the side wall 300 mm.

Gas connection

